

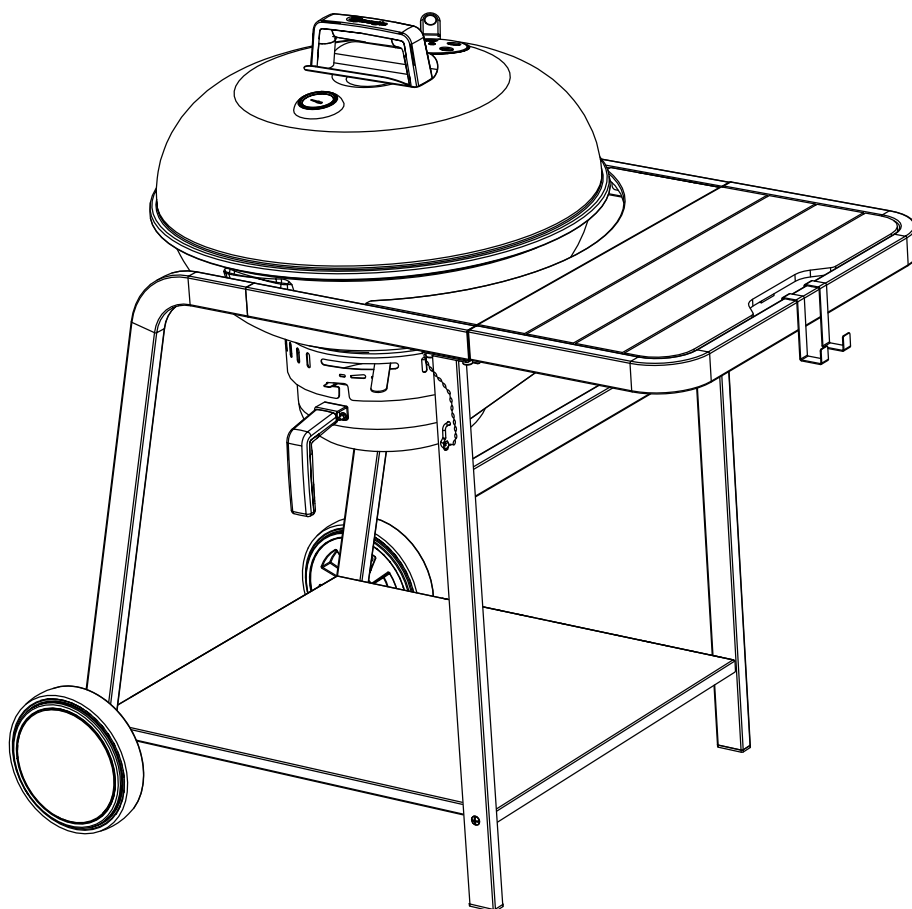

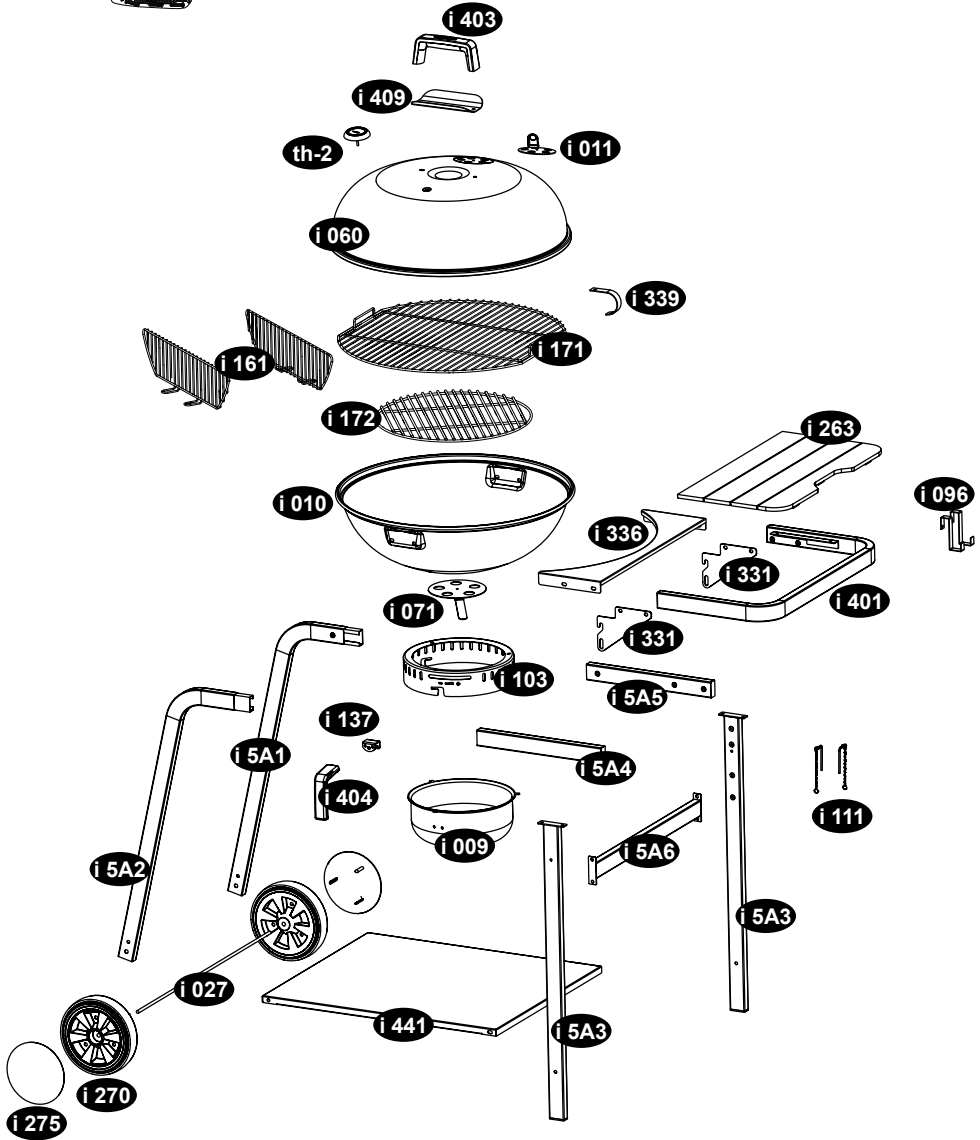







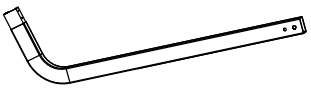

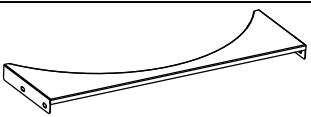

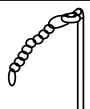





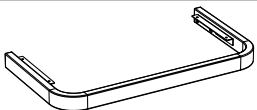
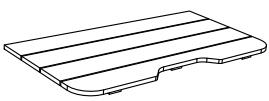
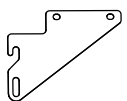
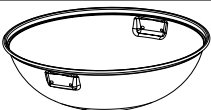
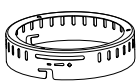

TOM 338570i EN

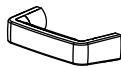









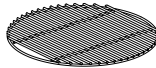















i 5A1		x 1
i 5A2		x 1
i 5A4		x 1
i 5A5		x 1
i 336		x 1
i 5A3		x 2
i 111		x 2
i 441		x 1
i 5A6		x 1
i 027		x 1
i 270		x 2
i 275		x 2

i 401		x 1
i 263		x 1
i 331		x 2
i 010		x 1
i 103		x 1
i 071		x 1
i 009		x 1
i 137		x 1
i 404		x 1
i 403		x 1
i 409		x 1
i 060		x 1

i 339		x 1
th-2		x 1
i 011		x 1
i 171		x 1

i 172		x 1
i 096		x 2
i 161		x 2
0181		x 1

	6 x 30	4
	6 x 12	16
	6 x 12	6
	6 X 12	4
	6 x 12	4
	4 x 12	4
	3,5 x 9,5	8
 brake nut/frein	Ø 8	2
	Ø 6	7

	Ø 4	3
 brake nut/frein	Ø 4	1
	Ø 8	1
	Ø 6	4a
	Ø 6	15b
 fiber/fibre	Ø 6	1
	Ø 4	8
 fiber/fibre	Ø 4	1
	Ø 8	1
	5	1

1 $\text{Ø}3,5 \times 9,5$ 

x 4

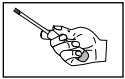
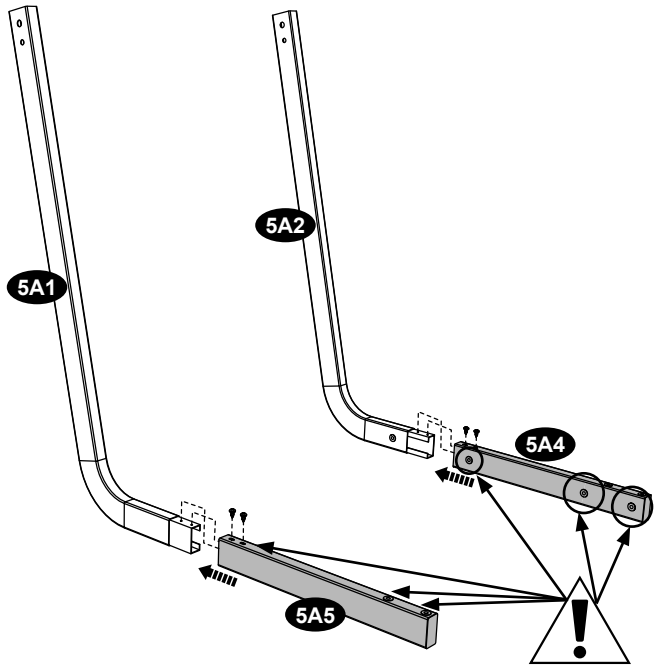
**2** $\text{Ø}6 \times 12$ 

x 4

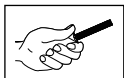
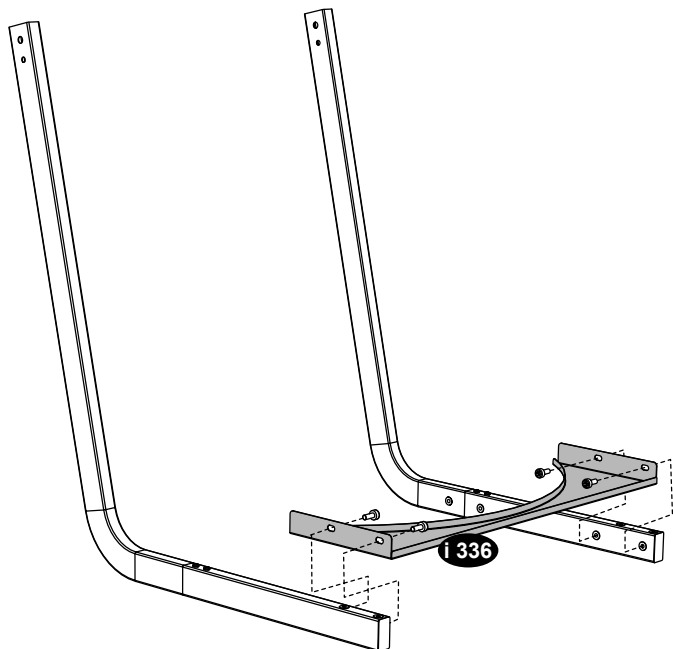

3

Ø6 x 12

Ø6



x 4

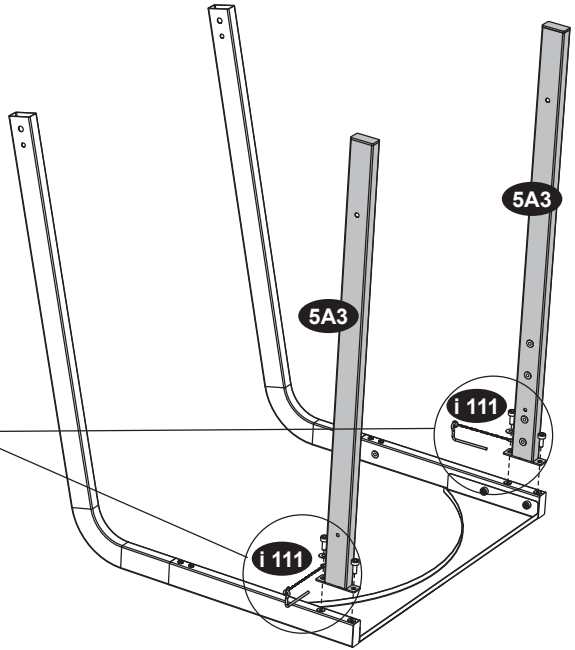
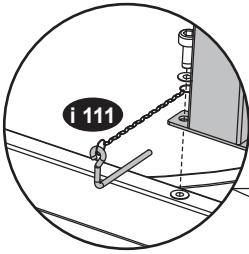

x 2

**4**

Ø6 x 30

Ø6

Ø6



x 4



x 4



x 4

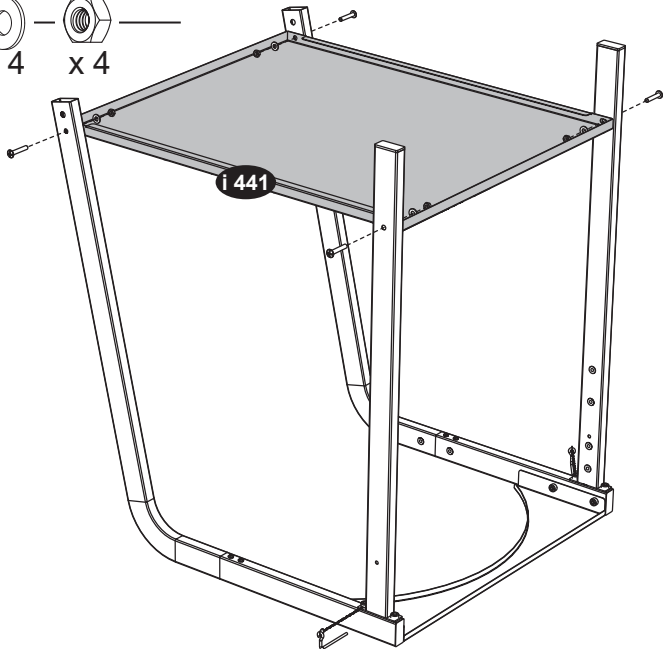

5 Ø6 x 12



x 4



x 1

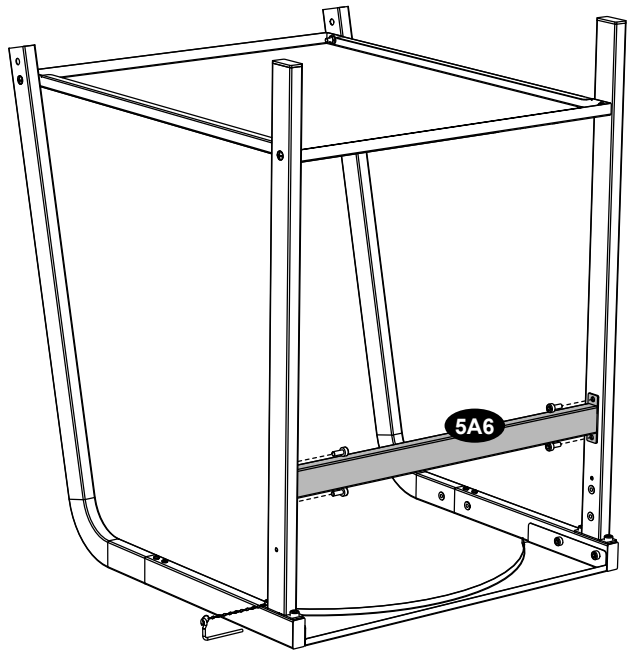

6

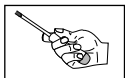
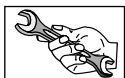
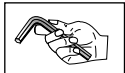
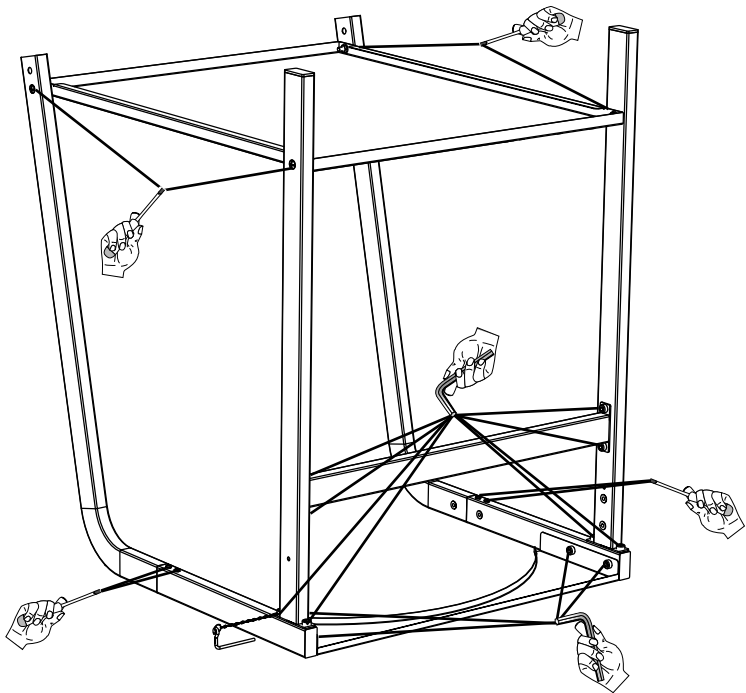

7

Ø 8

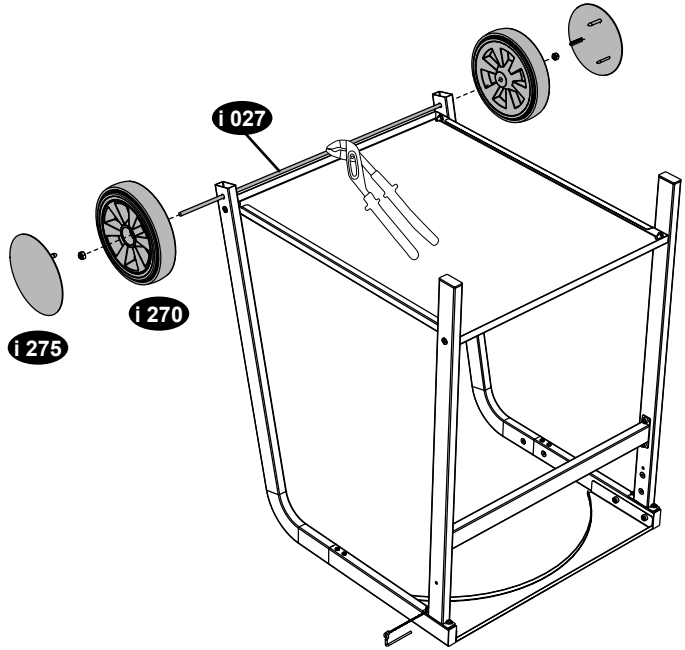

x 2

**8**

Ø3,5 x 9,5



x 4

Ø4



x 4

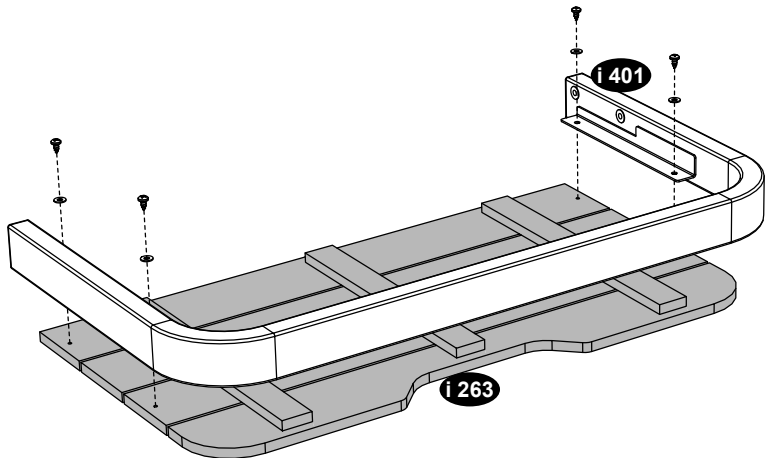

9

Ø6 x 12



x 4

5

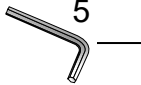

x 1

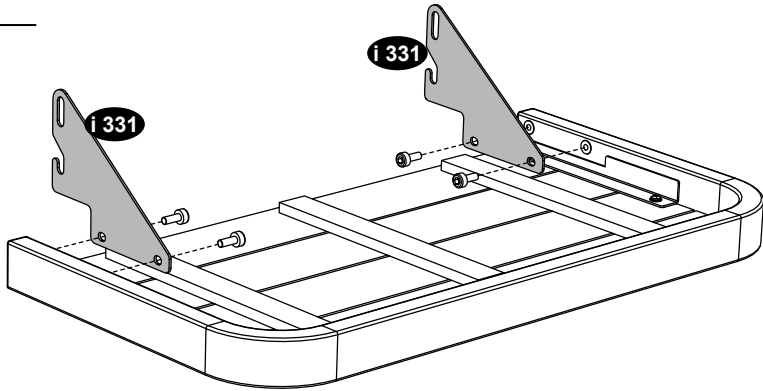
**10**

Ø6 x 12



x 2

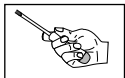

11

Ø6 x 12

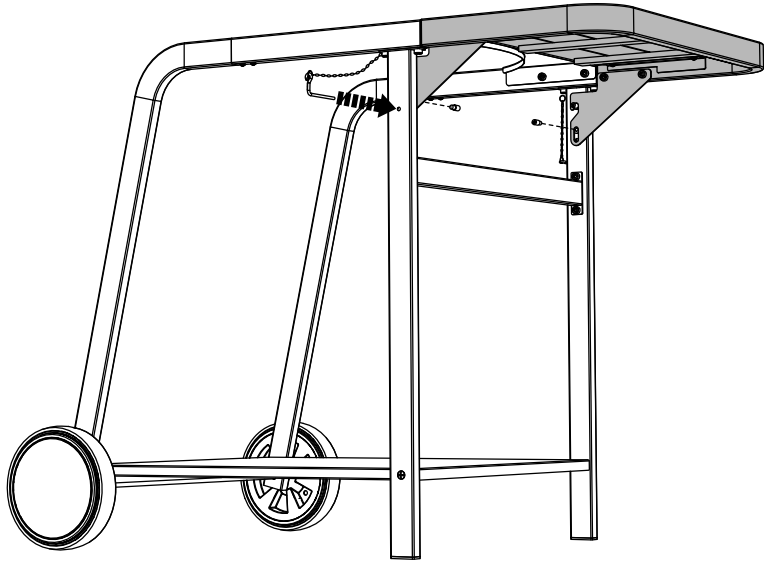
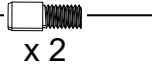
**12**

Ø6 x 12



Ø6



Ø6

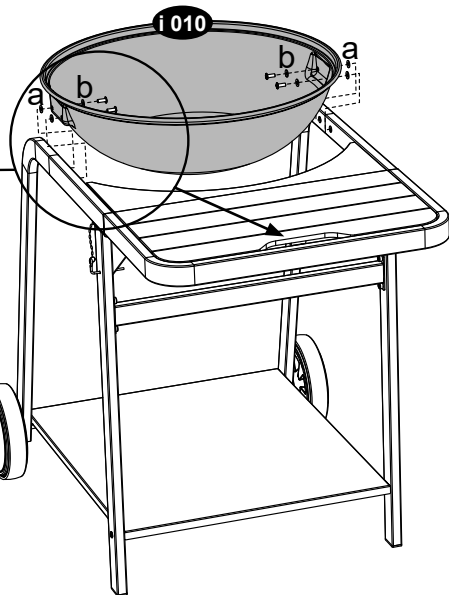
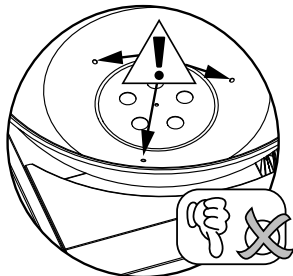
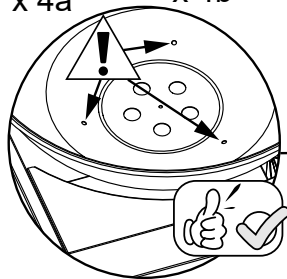

13

Ø6 x 12

Ø6

Ø6



x 3

x 3

x 3

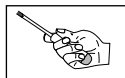
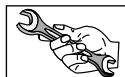
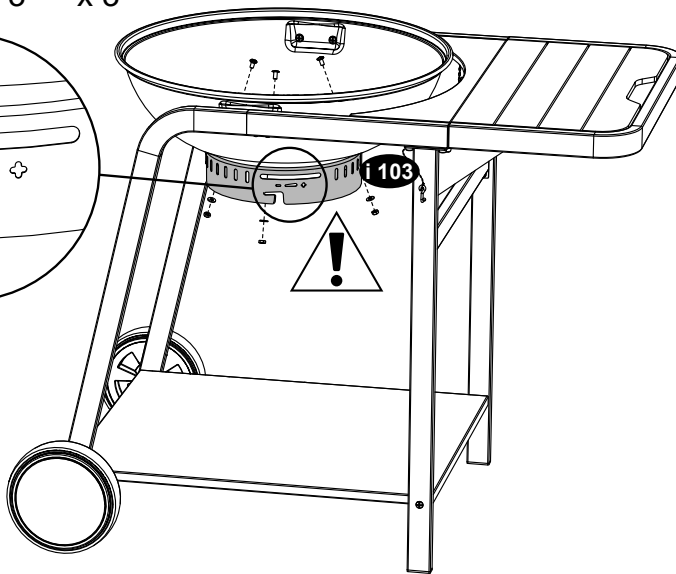
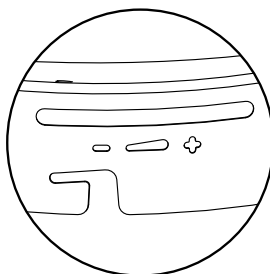
**14**

Ø4 x 12

Ø4

Ø4





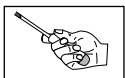
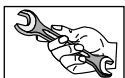
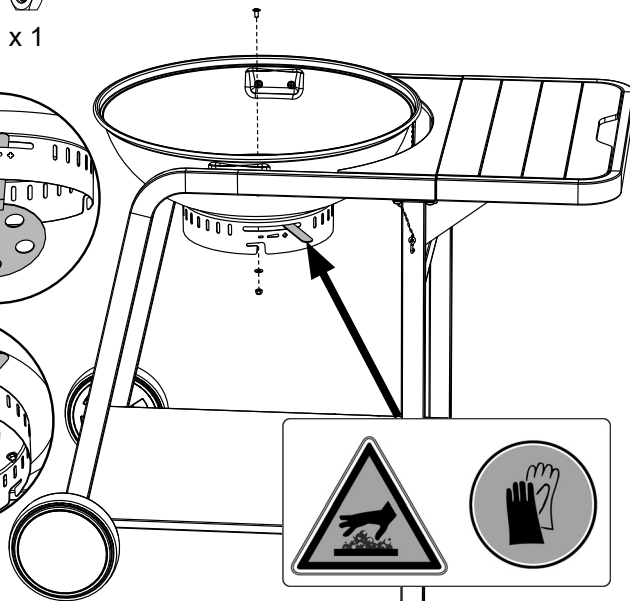
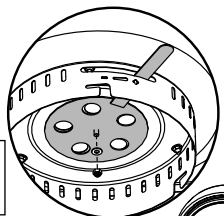
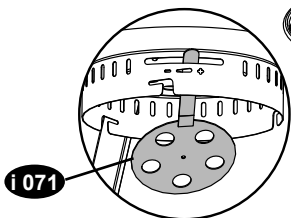

x 1

x 1

x 1



15

- | | | | |
|---|---|---|---|
|  |  |  |  |
| Ø6 x 12 | Ø4 x 12 | Ø4 | Ø4 |
| x 1 | x 2 | x 2 | x 2 |

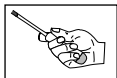
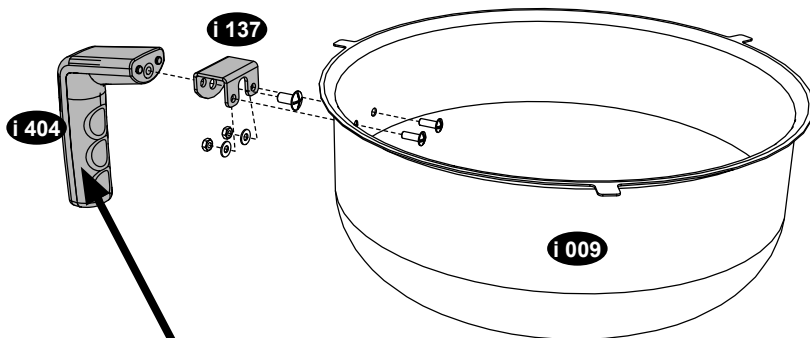
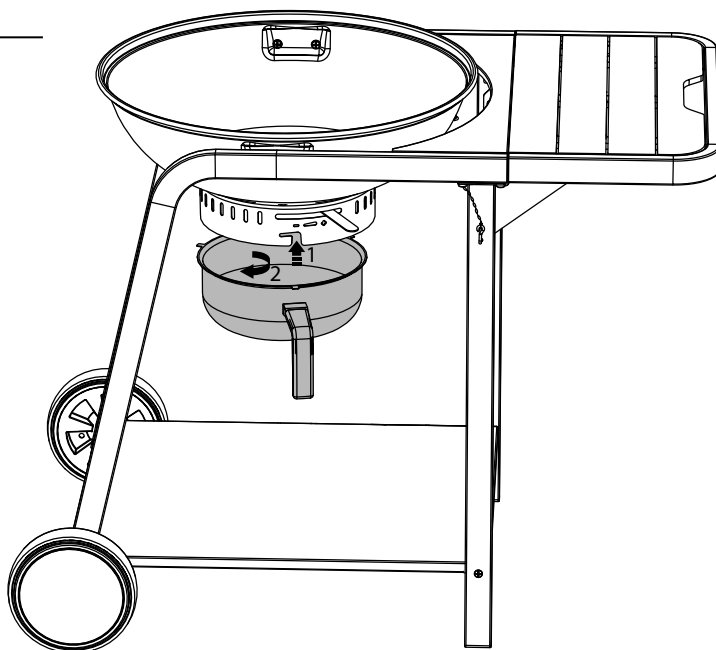
**16**

17

$\varnothing 6 \times 12$ $\varnothing 6$ $\varnothing 6$
 x 2 x 2 x 1a
 fiber/fibre

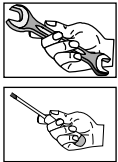
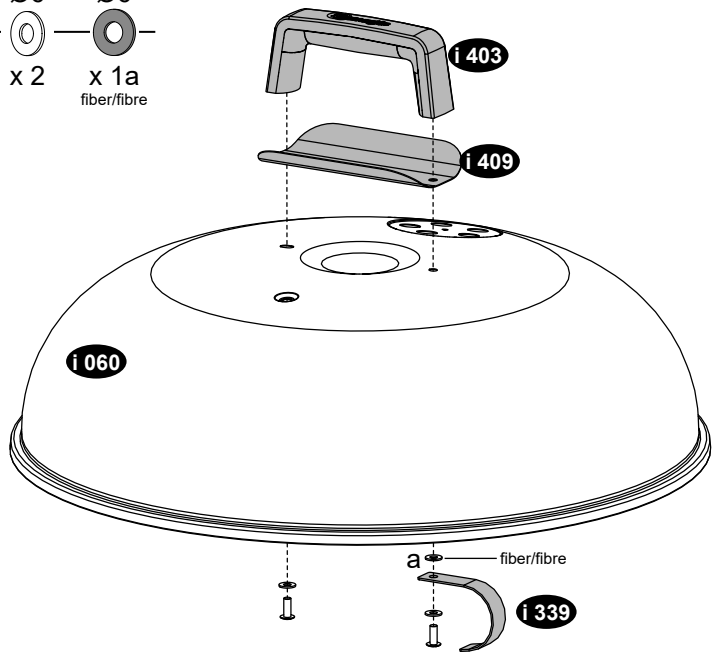
**18**

$\varnothing 4 \times 12$ $\varnothing 4$ $\varnothing 4$ $\varnothing 4$ $\varnothing 8$ $\varnothing 8$
 x 1 x 1a x 1b x 1 x 1 x 1c
 fiber/fibre
 brake
 nut/frein

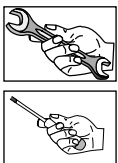
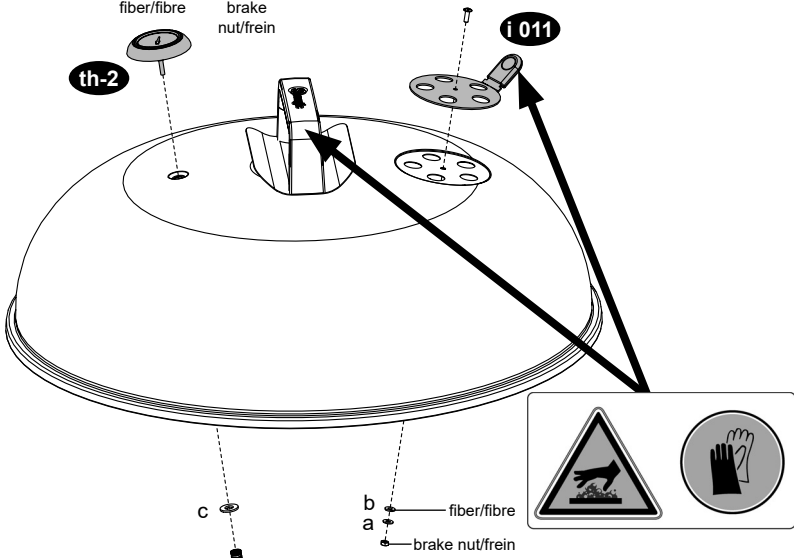

19

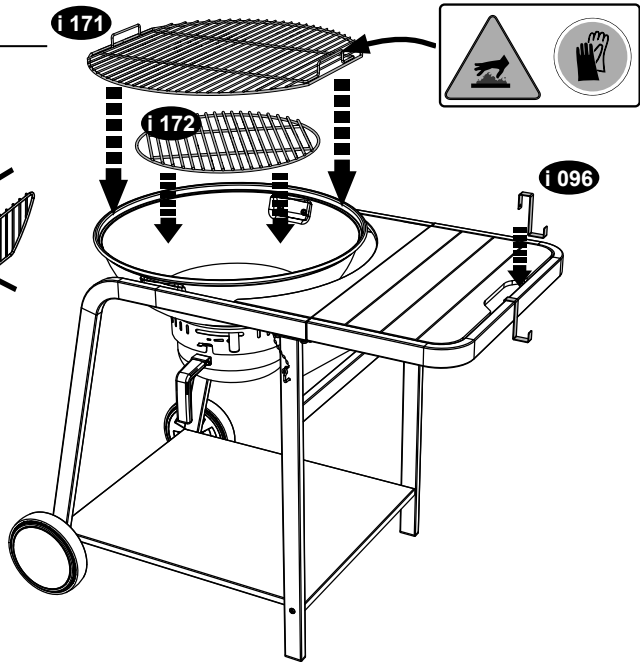

20

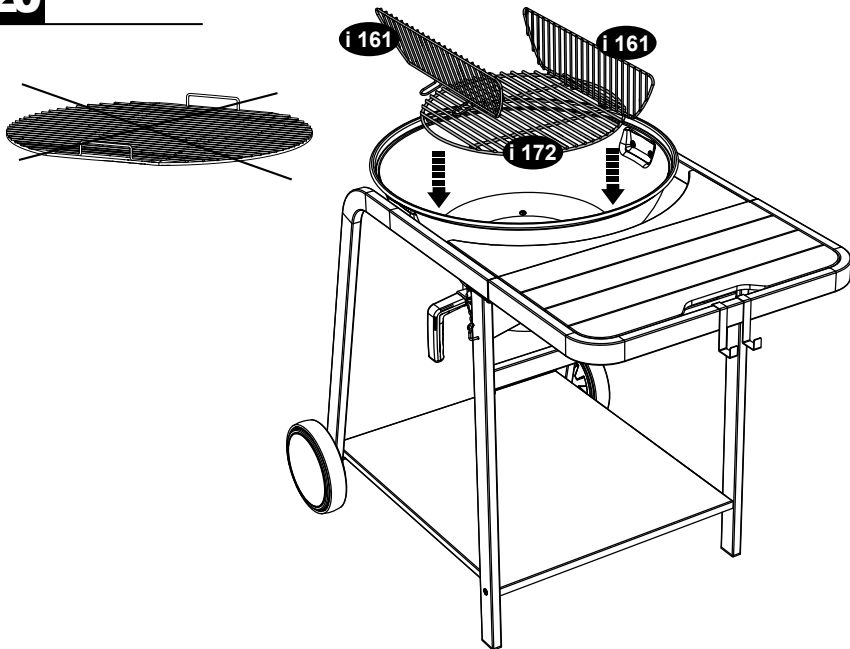

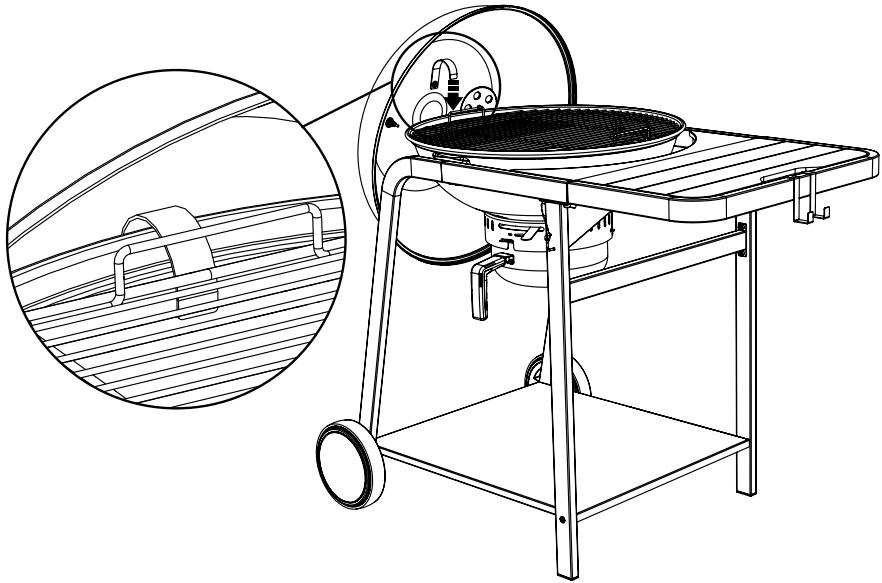

Cuisson directe

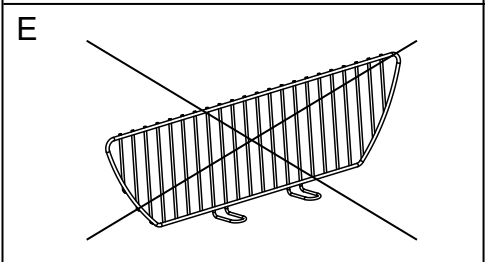
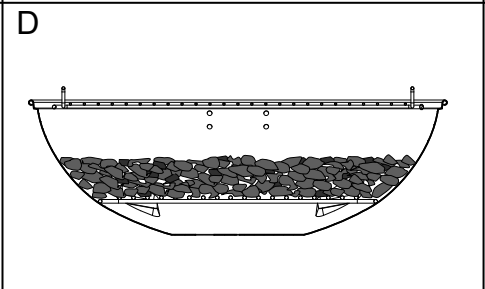
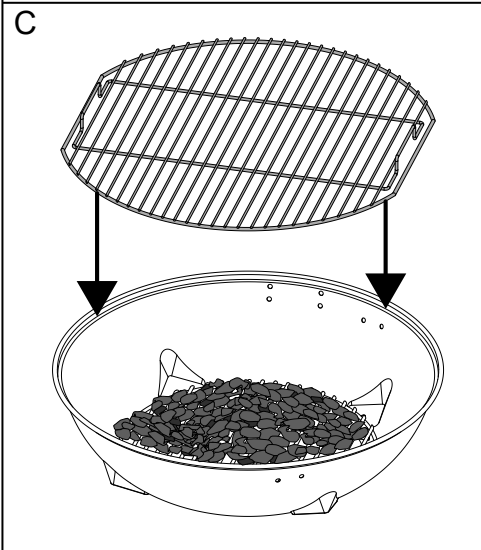
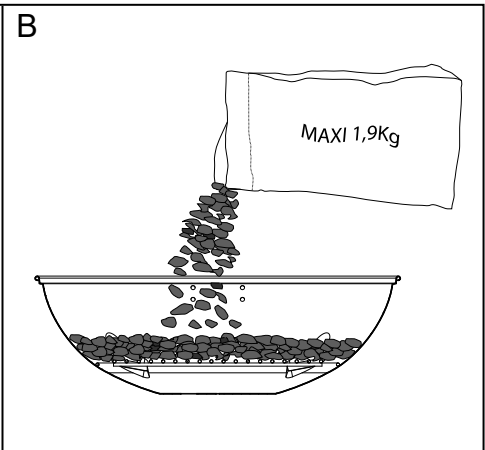
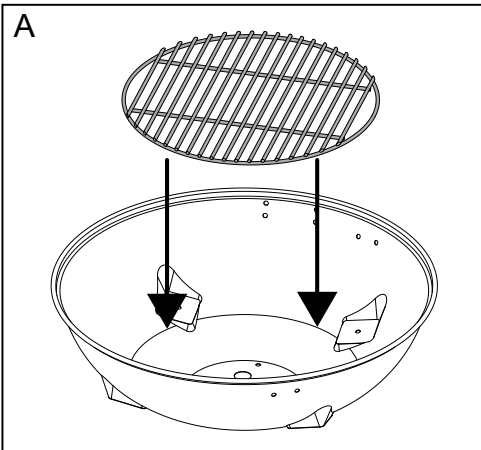
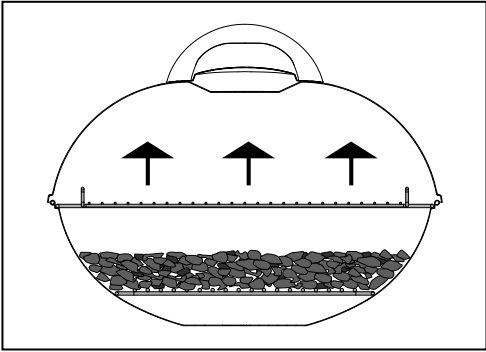

Cuisson indirecte

