

INDUCTION HOB WITH INTEGRATED HOOD

PIHS 8BL002 F8A70



FEATURES

- A++
- 8 Flex
- Slider
- Booster

SAFETY

- Child lock
- Overflow
- Overheating

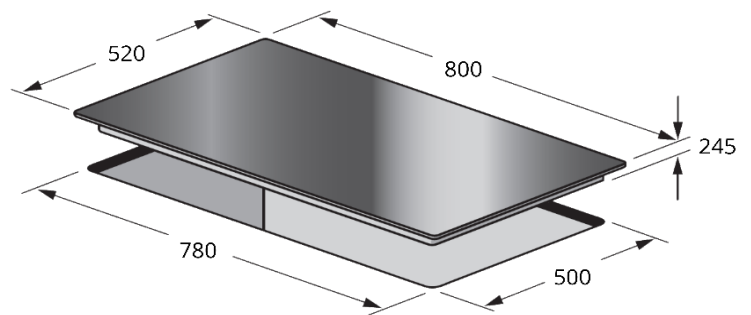
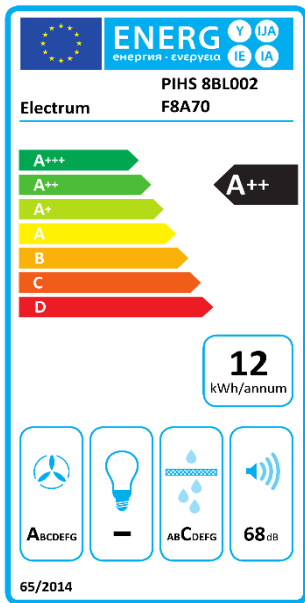
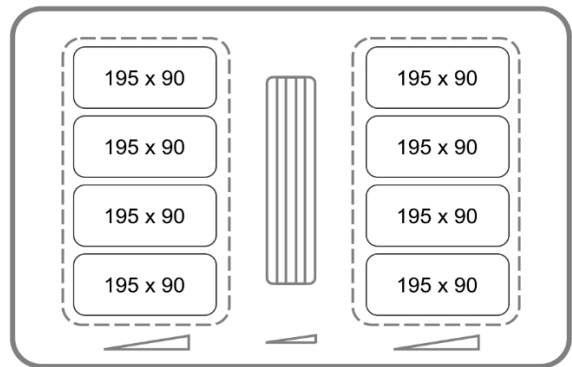

EAN 5425025901654

Tiptoetsen / touches sensibles / Soft touch		
Slider		●
Kleur / couleur / colour		BLACK
AFZUIGKAP / HOTTE / HOOD		
Energieklasse / classe énergétique / energy efficiency class		A++
Klasse motor / classe du moteur / fluid dynamic class		A
Klasse vetfilter / classe filtre à graisse / grease filtering class		C
Afzuiging / aspiration / suction power : min. - max. - boost (m ³ /h)		324 / 569 / 722
Geluidsniveau / niveau sonore / noise level : min. - max. - boost (dBa)		47 / 62 / 68
Vermogen motor / puissance moteur / motor power (W)		160
Clean Air		●
Stroom onderbrekende timer / minuterie coupe courant / cut-off timer		●
Afvoerkit / kit d'évacuation / Exhaust kit		●
Koolstoffilter type / type filtre à charbon / charcoal filter type		●
KOOKPLAAT / PLAN DE CUISSON / HOB		
Zone 1 - Ø mm / W	210 x 190	2200/3600
Zone 2 - Ø mm / W	210 x 190	2200/3600
Zone 3 - Ø mm / W	210 x 190	2200/3600
Zone 4 - Ø mm / W	210 x 190	2200/3600
Flex	-	3300/3700
Totaal vermogen / puissance totale / total power (W)		7400
Kook niveaus / niveaux de puissance / cooking levels		9
KENMERKEN / CARACTÉRISTIQUES / FEATURES		
Variabele zones / zones variables / extended zones		FLEX
Stroom onderbrekende timer / minuterie coupe courant / cut-off timer		4
Timer / minuterie / Egg timer		
Booster		●
Flex-Pro		●
Chef functie / mode chef / chef mode		
Pauze / pause / pause		●
Geheugen / mémoire / memory		
Auto keep warm (°C)		40 / 75 / 90
VEILIGHEID / SÉCURITÉ / SAFETY		
Kinderbeveiliging / verrouillage enfants / child lock		●
Onvrijwillig opzetten / allumage involontaire / unintentional turn-on		●
Overkoken / anti-débordement / overflow		●
Oververhitting / surchauffe / overheating		●
Tijdlimiet / limitation de durée / time limitation		●
AANSLUITING / RACCORDEMENT / CONNECTION		
Power management		
220 - 240V 1N~		●
220 - 240V 2L+2N~		●
380 - 415V 2N~		●
380 - 415V 3N~		●
Frequentie / Fréquence / Frequency (Hz)		50/60
VERZENDING / EXPÉDITION / SHIPMENT		
B x D x H / L x P x H / W x D x H (mm)		920 x 655 x 512
Netto / net / net (kg)		25,00
Bruto / brut / gross (kg)		34,00
EAN		5425025901654