

ASSEMBLY INSTRUCTIONS

MOTORIZED CURTAINS 3, 4, 5 AND 6M

RE3MDGS / RE3MDNS
RE4MDGS / RE4MDNS
RE5MDGS / RE5MDNS
RE6MDGS / RE6MDNS

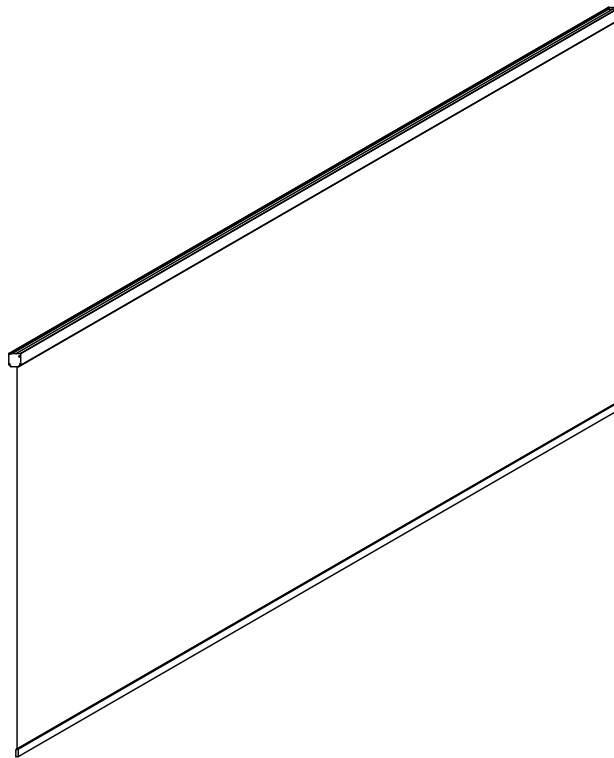

Before starting assembly of your product, make sure you wear the necessary personal protective equipment and consult the assembly instructions.



sav@green-outside.com



LE TRI + FACILE NOTICE PAPIER & CARTON



PAP

TABLE OF CONTENTS

1. SAFETY INFORMATION AND INSTRUCTIONS	-----	P.3
1.1 Tools needed	-----	p.3 p.3
1.2 Safety instructions	-----	p.3
1.3 Unpacking and checking the contents	-----	p.3
1.4 Maintenance Tips	-----	
2. LIST OF COMPONENTS	-----	P.4
3. CURTAIN INSTALLATION	-----	P5
4. REMOTE CONTROL DESCRIPTION	-----	P.12
5. PAIRING THE ELECTRIC CURTAIN	-----	P.12
6. TROUBLESHOOTING & FREQUENTLY ASKED QUESTIONS	-----	P.13
7. WARRANTY AND CONTACT	-----	P.14

1. SAFETY INFORMATION AND INSTRUCTIONS



1.1 Tools needed

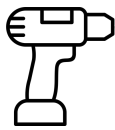

1 screwdriver



1 caulking gun with cartridge

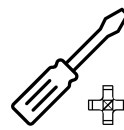

1 Phillips screwdriver (PH1)



1 stepladder / person

1.2 Safety instructions

To ensure the safe assembly of your product, certain rules must be followed:

- Wearing personal protective equipment is strongly recommended (gloves, safety shoes, goggles, etc.)
- Keep children away from the construction site
- Choose a suitable location for mounting your product (flat, hard ground allowing for solid anchoring, not subject to strong winds)
- Ensure that the fixing points do not coincide with cable passages, conduits or other pipes.
- In the case of installing a pergola, provide a ground with a 1% slope to allow for the drainage of rainwater.
- Do not attempt assembly in adverse weather conditions (rain, wind, snow, etc.)
- In case of bad weather (wind, rain, snow) it is recommended to keep the blades in a semi-open position to promote airflow and prevent snow accumulation.
- To ensure the safety of the installation and the longevity of the components, the electrical elements (transformer, remote control, etc.) must be installed in a dry, well-ventilated, and frost-free environment. Any exposure to humidity or extreme temperatures will void the warranty. Note that the use of a weatherproof power outlet is mandatory for any outdoor connection.

1.3 Unpacking the product





When opening the boxes, be careful not to use a box cutter or any blade that could damage the product. The boxes are labeled with the components inside. Make sure you have all the items listed in the components list and that they are correct before you begin assembling your product.

1.4 Maintenance Tips

- We recommend regularly cleaning your product by removing leaves, branches, or other elements that could impair its proper functioning.
- Your product can be cleaned with soapy water.
- Never use a high-pressure cleaner, corrosive products, or solvents.

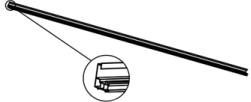
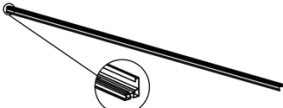
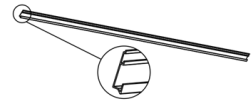
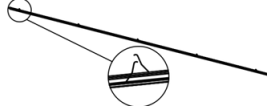
In the event that a component is missing, damaged, or if you have any doubts, please contact Green Outside customer service:
sav@green-outside.com

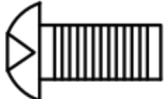
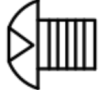
2. List of components

Reference	Component	Quantity	Representation
A	Rideau	1	
B1	Right rail	1	
B2	Left rail	1	
C	Rail cover	2	
D	Slide	2	
AND	Mounting bracket	3 / 4*	
1	Show M5x16	6 / 8*	
2	Vis M5x8	3 / 4*	
3	Vis autoforeuse ST5.5x25	6	
4	All ST2.9x13	6	

Quantities marked with an asterisk () refer to 5M and 6M curtains (RE5MDGS / RE5MDNS / RE6MDGS / RE6MDNS) only.

3. Curtain assembly

A N D 1	 x3 / x4* x6 / x8*	<ul style="list-style-type: none"> Place the fixing brackets (E) on the underside of the pergola beam.
--------------------------------	---	---

* For the 3m and 4m versions: Install 3 plates (E) using 6 screws (1).
 For the 5m and 6m versions: Install 4 plates (E) using 8 screws (1).



Orient the return of the fixing bracket (V-shaped) towards the inside of the structure (gutter side).

- Locate and remove the M4x8 retaining screws located at both ends of the curtain housing.
- Tilt and remove the movable lid of the trunk.
- Keep these parts (screws and lid) safe for the final closing step.

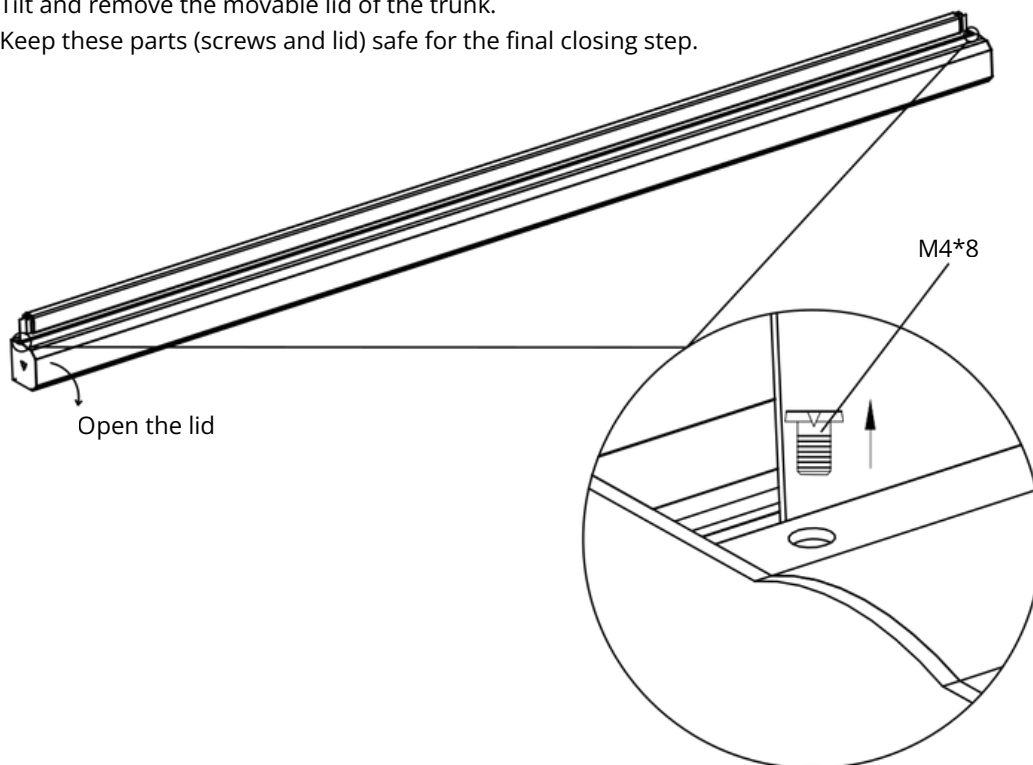

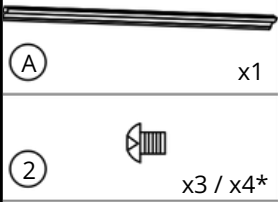

Hanging: Position the curtain (A) facing the previously installed fixing brackets (E). Engage the top profile of the curtain into the lugs of the fixing brackets. Secure the assembly by inserting the M5x8 screws (2) at an angle into the holes provided for this purpose.

- 3m/4m models: Use 3 screws (2).
- 5m/6m models: Use 4 screws (2).

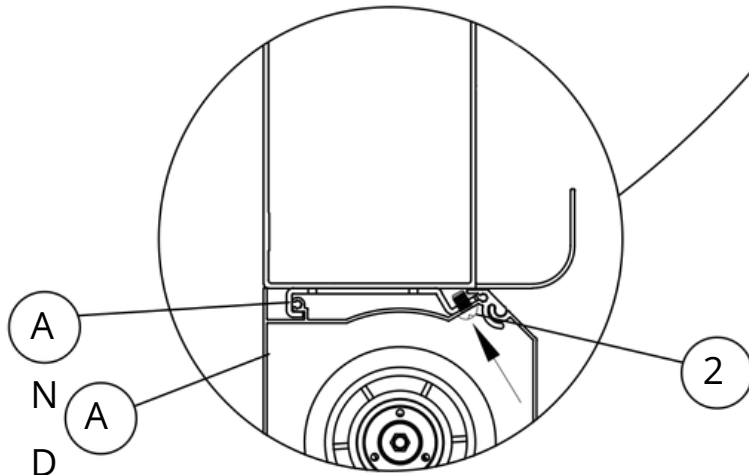
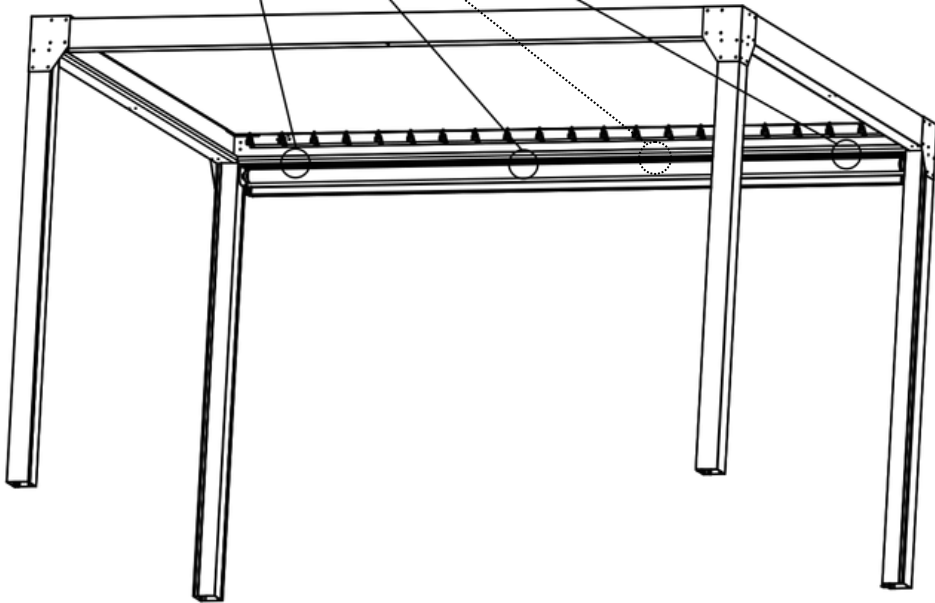
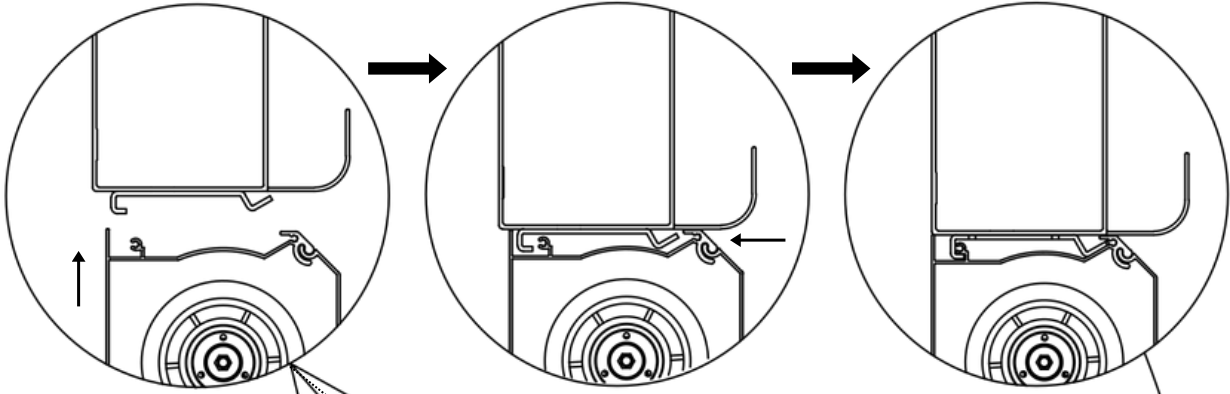

- Reposition the movable cover onto the curtain body.
- Secure the lid by reinstalling the M4x8 screws at each end. Ensure the lid is perfectly aligned to guarantee a watertight seal.

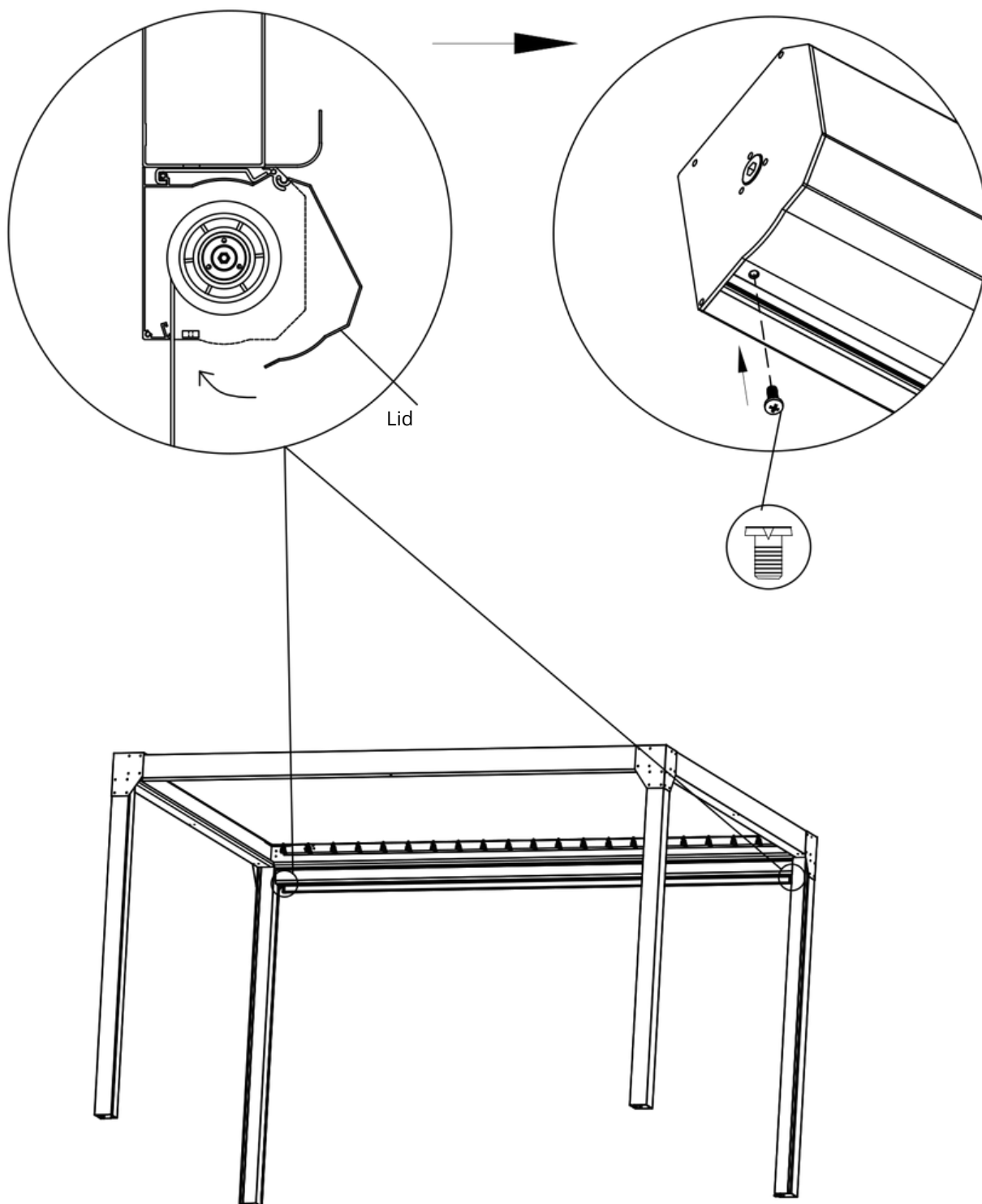

- Connect the electrical plugs.
- Once the connection has been made and tested, conceal the excess wiring inside the pergola support column for a neat finish.

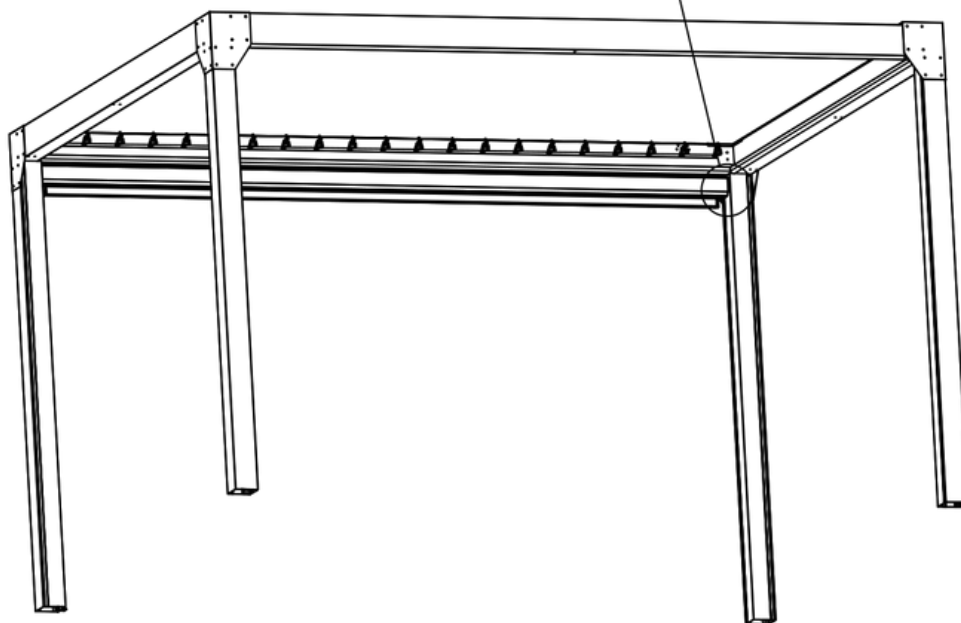
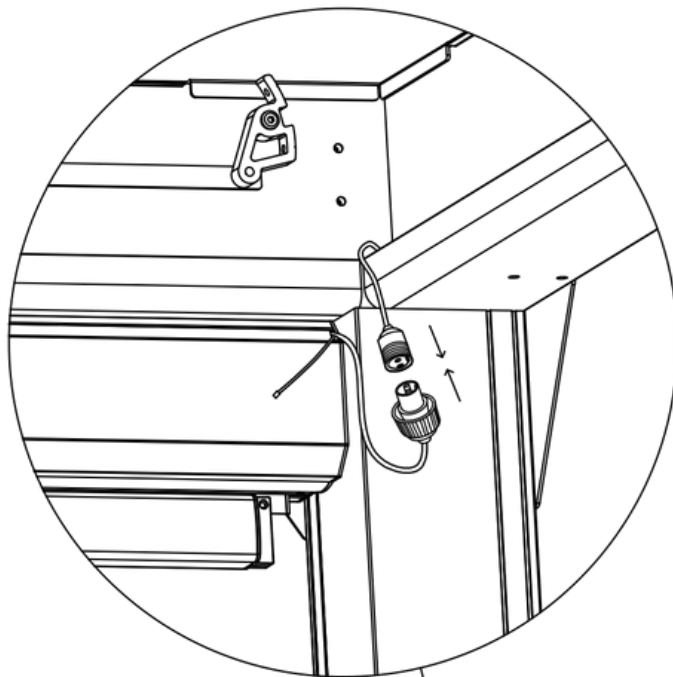

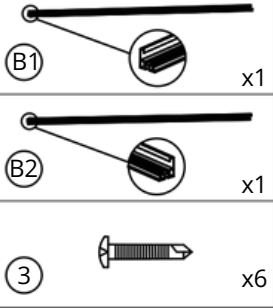

Position the rails (B1) and (B2) on each side of the opening, against the pergola posts. Strictly observe the installation direction: the guide notches must be oriented upwards.

Secure the rails to the posts using the 6 self-drilling screws (3) (3 screws per rail).

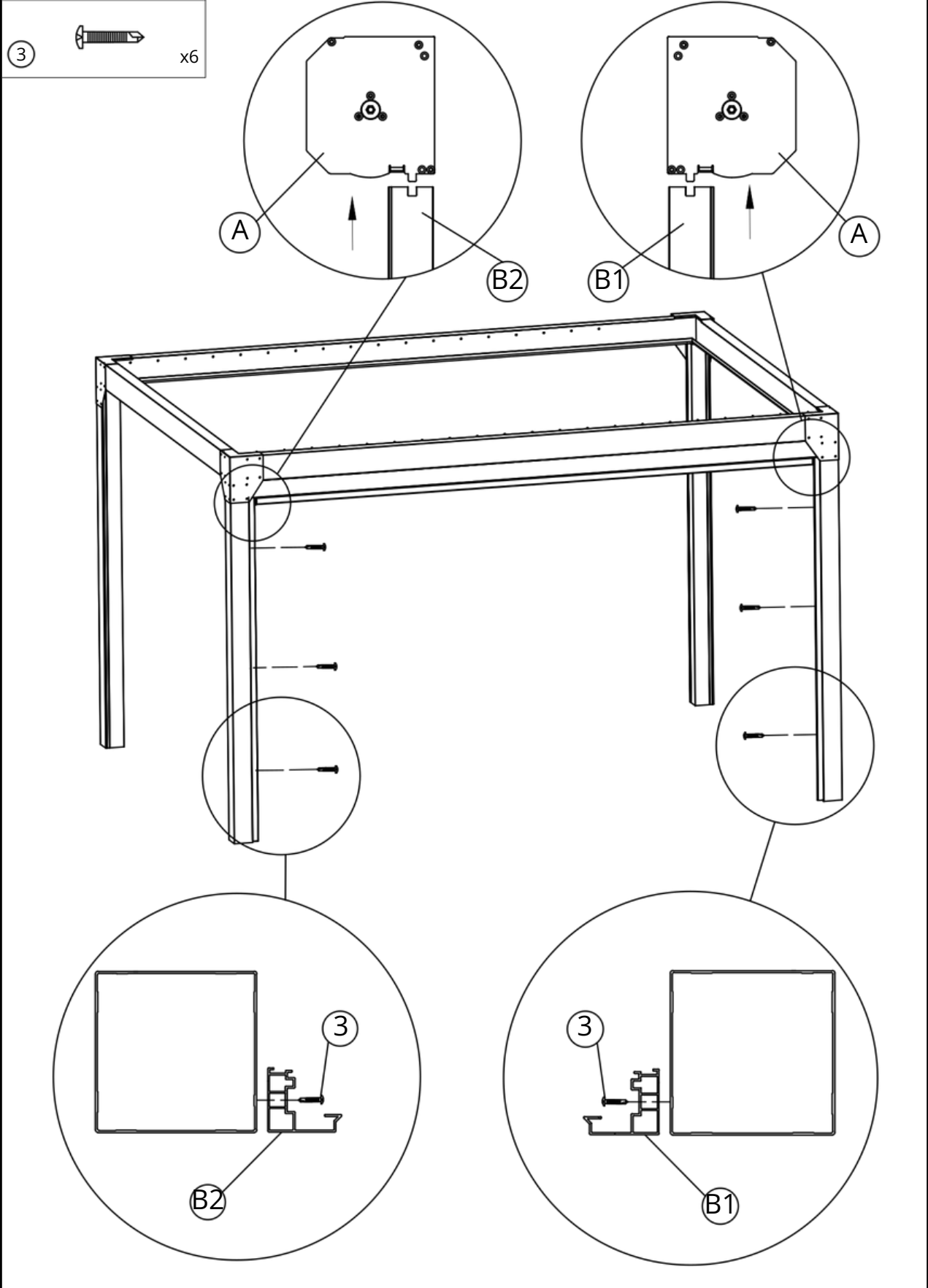

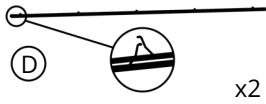

Ensure that all slots (D) on both sides of the roller blind are installed before proceeding to the next step.

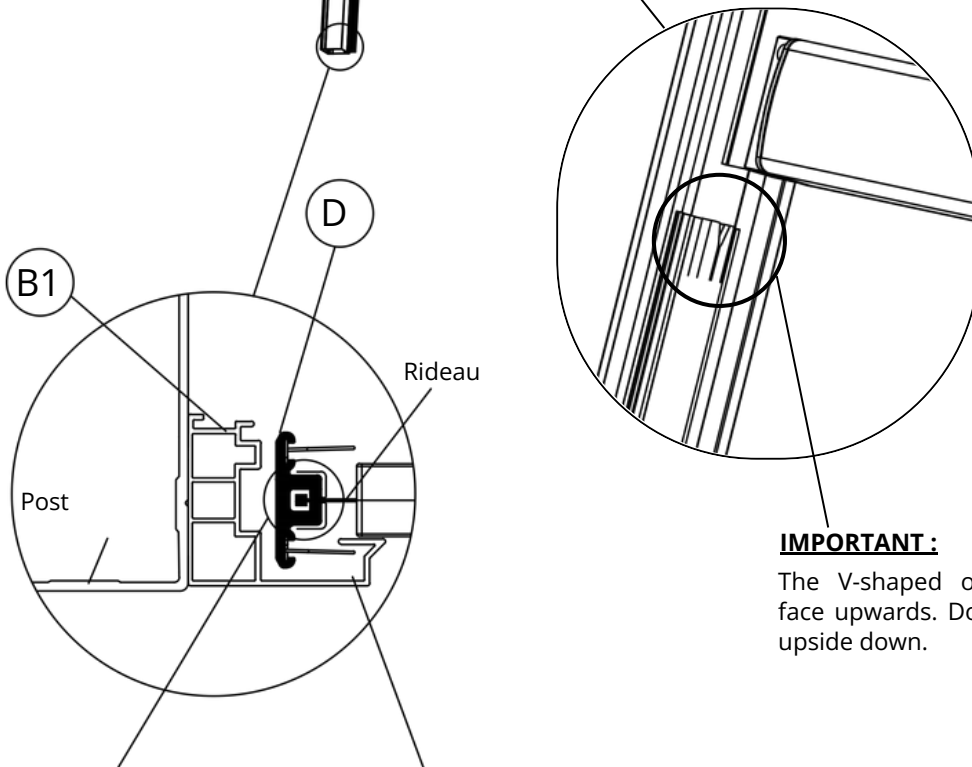
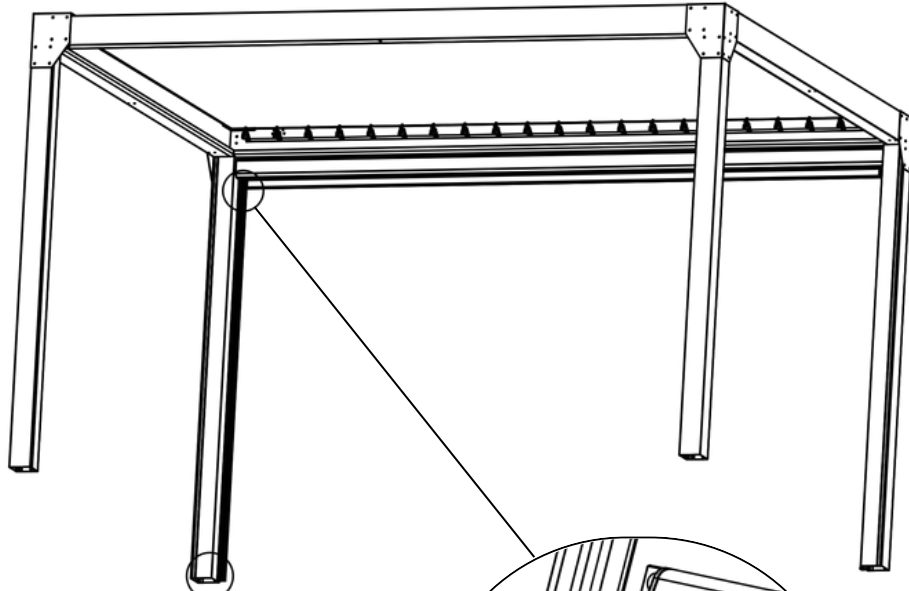

IMPORTANT :

The V-shaped opening must face upwards. Do not install it upside down.

The zipper located on the edge of the fabric must be inserted into the groove of the card slot.

Note that after installation, make sure that the spring is also in the groove indicated on the diagram.

Insert the zipper (Zip) located on the edge of the curtain fabric into the groove of the slider (D). Insert the assembly into the guide rail. Ensure that the springs are correctly seated in the groove.

The "V" shaped opening of the slide must be facing upwards. Reversing it would prevent the curtain from deploying properly.

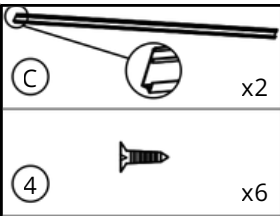

Install the finishing side panels (C) over the guide rails.
Secure the covers using the 6 screws (4) (3 screws per side).

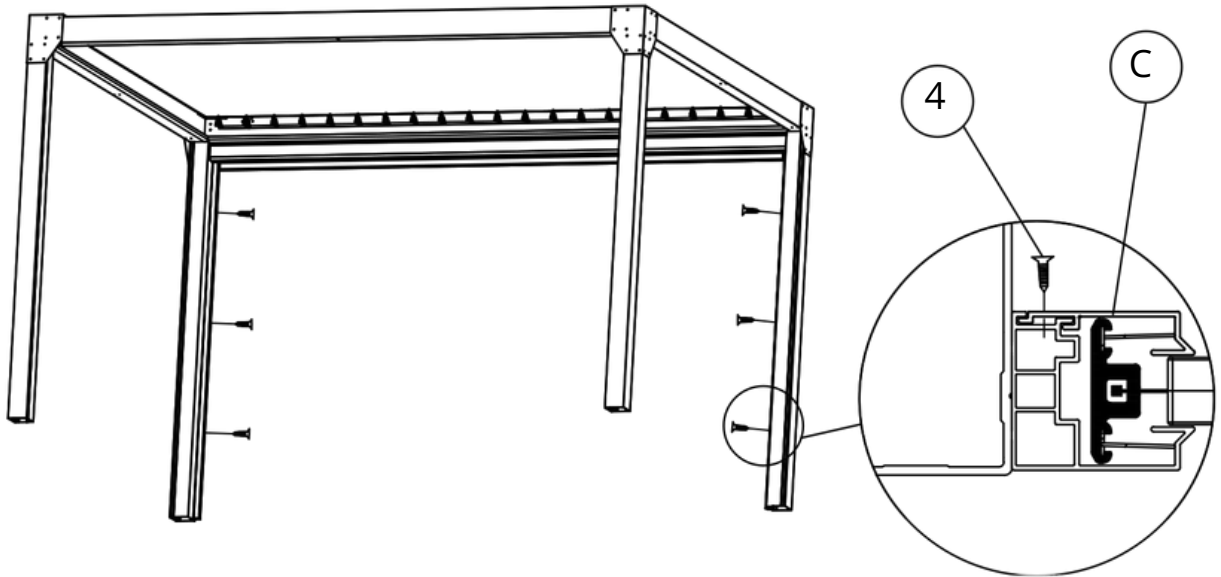

4. Remote control description

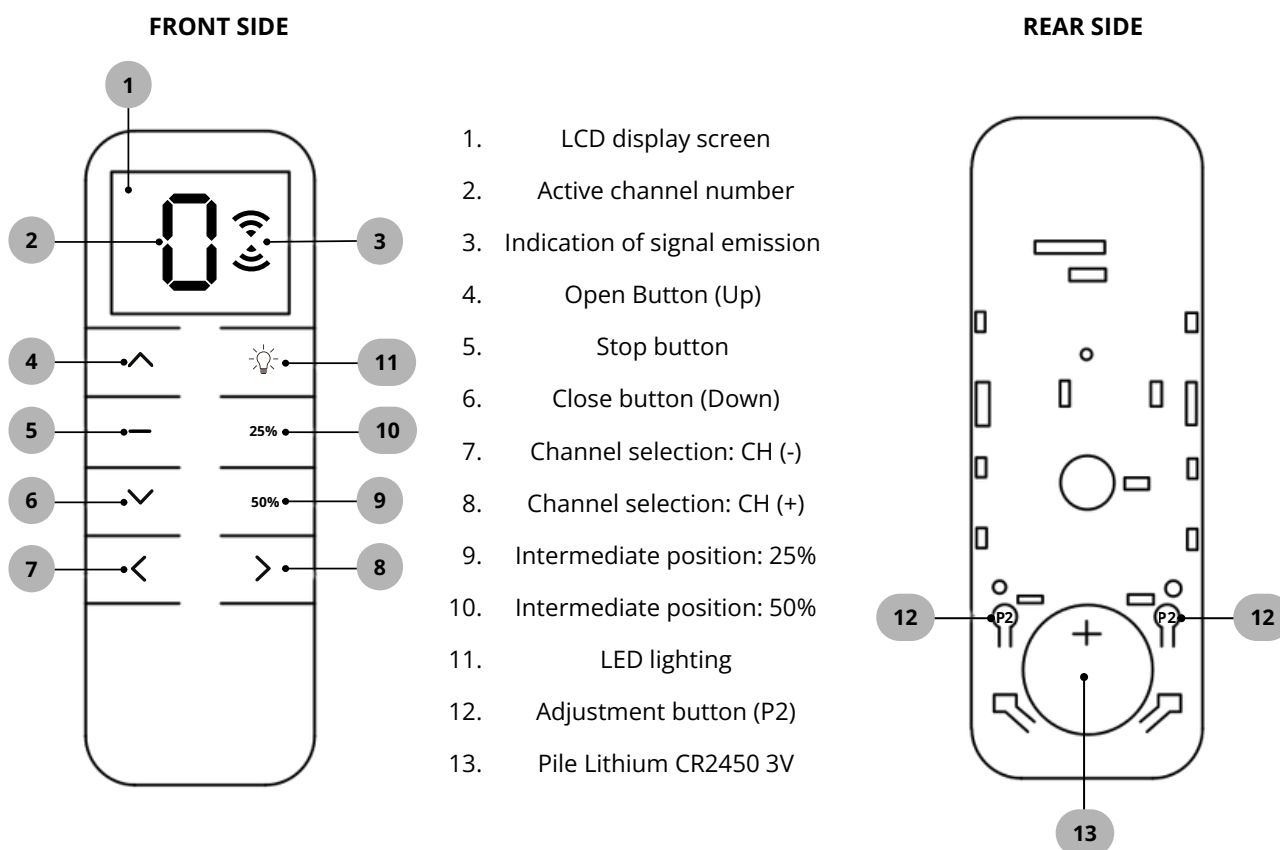

5. Pairing the electric curtain

Once the installation of an electric curtain is complete, it is necessary to pair it with its channel by following the pairing procedure:



Select a channel using the right and left arrows.
Select channel 3 during the first pairing test.

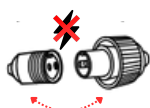

Disconnect the curtain's wiring

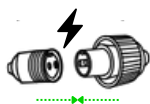

Reconnect the curtain's wiring. The motor responds.



Press "P2" for 1 second. The motor reacts: 1 beep, 1 movement



Press "P2" for 1 second. The motor reacts: 1 beep, 1 movement



Press the up arrow for 1 second. The motor will react: 3 beeps.
Your curtain pairing is complete.

If the motor does not respond during the last step, please restart the pairing process by selecting a different channel. Select the channels in order, 3 then 4, and so on until pairing is complete.

The curtains, pergolas and remote controls are pre-configured in the workshop so that the settings are optimal when starting up.

5. Troubleshooting & Frequently Asked Questions

- **Do I need to take any steps before installing my products?**

Installing a bioclimatic pergola, carport or garden shed requires some administrative procedures depending on its dimensions and location.

Our garden sheds have a footprint of 5m² to 20m² and are subject to prior declaration of works. For our models smaller than 5m², you do not need planning permission, but you must still comply with the rules of the Local Urban Development Plan (PLU) or equivalent urban planning document.

Bioclimatic pergolas and carports with a surface area greater than 5m² and less than or equal to 20m² are subject to prior declaration of works.

For bioclimatic pergolas and carports with a surface area greater than 20m², you must submit a building permit application.

Special cases:

- Classified site or protected area: before any installation, it is necessary to obtain the agreement of the Architects of the Buildings of France (ABF).
- Condominium regulations: if you are in a condominium, authorization from the general meeting may be required.
- Local Urban Planning (PLU): some municipalities have specific restrictions (height, color, materials), it is advisable to consult the town hall before purchasing a product.

The development tax:

Garden sheds larger than 5m² are subject to the development tax, unless exempted by the municipality. The amount is calculated on a flat-rate basis per m² and varies depending on the location.

- **Can I order the accessories for my bioclimatic pergola at a later date?**

Yes, our bioclimatic pergolas are modular. Various accessories can be added later. Please be careful to check the compatibility of the accessories with your pergola model before placing your order.

- **How does the delivery of my products work?**

Our garden sheds, bioclimatic pergolas, glass walls, mosquito nets, and sunshades are delivered by a carrier. They will contact you to schedule a delivery appointment, which will be made using a semi-trailer equipped with a forklift.

Our curtains are delivered by a traditional carrier.

For a stress-free assembly, find all our assembly instructions in video format on our YouTube page and on our website by clicking on the following link or by scanning the QR code.

<https://www.youtube.com/@greenoutside8067>



<https://green-outside.com/>



6. Warranty and contact

Your product is covered by a legal guarantee against any manufacturing defects. You can find the details of the Green Outside legal guarantee by clicking on the following link.

<https://green-outside.com/procedure-sav/>

or by scanning the QR code



For any warranty claim or in case of a problem with your product, please contact Green Outside customer service using the following contact details:

sav@green-outside.com

04 74 55 36 54 - Option 2

As part of its policy of continuous improvement, Green Outside reserves the right to modify its products without prior notice.

For more information on Green Outside products:
info@green-outside.com and www.green-outside.com