

ASSEMBLY INSTRUCTIONS

3M SLIDING PANEL

BSO3MCDNS / BSO3MCDGS
BSO3MCDB / BSO3MCDGB

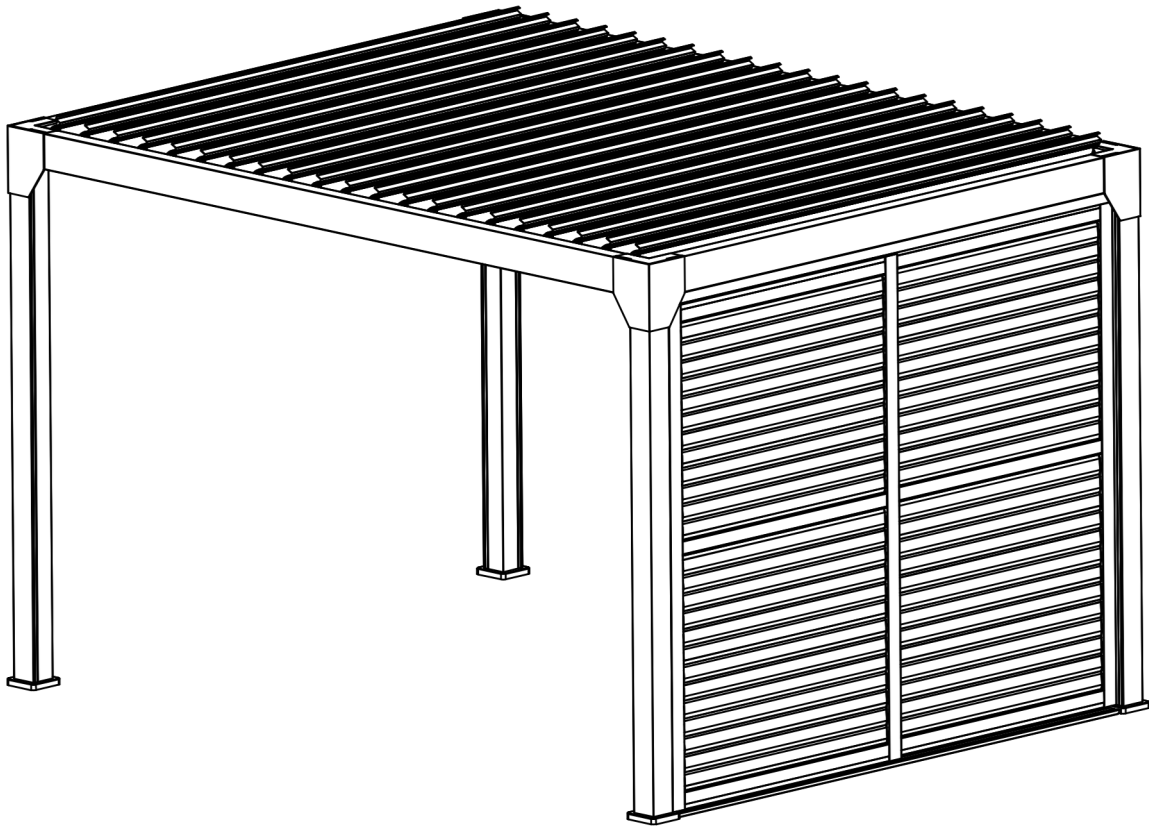

Before starting assembly of your product, make sure you wear the necessary personal protective equipment and consult the assembly instructions.



sav@green-outside.com



LE TRI + FACILE NOTICE PAPIER & CARTON



22
PAP

TABLE OF CONTENTS

1. SAFETY INFORMATION AND INSTRUCTIONS	-----	P.3
1.1 Tools needed	-----	p.3 p.3
1.2 Safety instructions	-----	p.3
1.3 Unpacking and checking the contents	-----	p.3
1.4 Maintenance Tips	-----	
2. LIST OF COMPONENTS	-----	P.4
3. PANEL ASSEMBLY	-----	P5
4. TROUBLESHOOTING & FREQUENTLY ASKED QUESTIONS	-----	P.10
5. WARRANTY AND CONTACT	-----	P.11

1. SAFETY INFORMATION AND INSTRUCTIONS



1.1 Tools needed

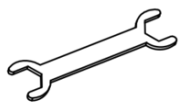

1 x 13/10 open-end wrench (INCLUDED)

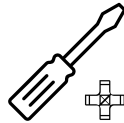

1 Phillips screwdriver (PH1)

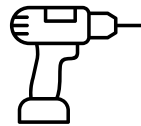

1 hammer drill / rotary hammer

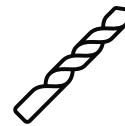

1 concrete drill bit Ø6



1 stepladder / person



1 hammer

1.2 Safety instructions

To ensure the safe assembly of your product, certain rules must be followed:

- Wearing personal protective equipment is strongly recommended (gloves, safety shoes, goggles, etc.)
- Keep children away from the construction site
- Choose a suitable location for mounting your product (flat, hard ground allowing for solid anchoring, not subject to strong winds)
- Ensure that the fixing points do not coincide with cable passages, conduits or other pipes.
- In the case of installing a pergola, provide a ground with a 1% slope to allow for the drainage of rainwater.
- Do not attempt assembly in adverse weather conditions (rain, wind, snow, etc.)
- In case of bad weather (wind, rain, snow) it is recommended to keep the blades in a semi-open position to promote airflow and prevent snow accumulation.

1.3 Unpacking and checking the product





When opening the boxes, be careful not to use a box cutter or any blade that could damage the product. The boxes are labeled with the components inside. Make sure you have all the items listed in the components list and that they are correct before you begin assembling your product.

1.4 Maintenance Tips

- We recommend regularly cleaning your product by removing leaves, branches, or other elements that could impair its proper functioning.
- Your product can be cleaned with soapy water.
- Never use a high-pressure cleaner, corrosive products, or solvents.

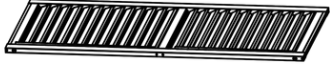
In the event that a component is missing, damaged, or if you have any doubts, please contact Green Outside customer service:
sav@green-outside.com

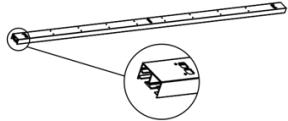
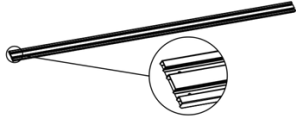
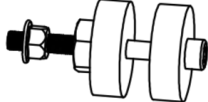
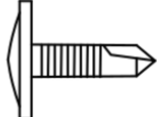
2. List of components

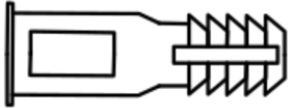
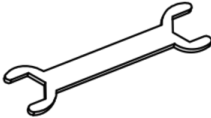
Reference	Component	Quantity	Representation
A	Left leaf	1	
B	Right leaf	1	
C	Top Rail	1	
D	Rail bas	1	
AND	Roulette	4	
1	Vis autoforeuse 5x14	20	
2	Vis M4x30	20	
3	6x30mm Anchor	20	
4	13/10 open-end wrench	1	

3. Panel mounting

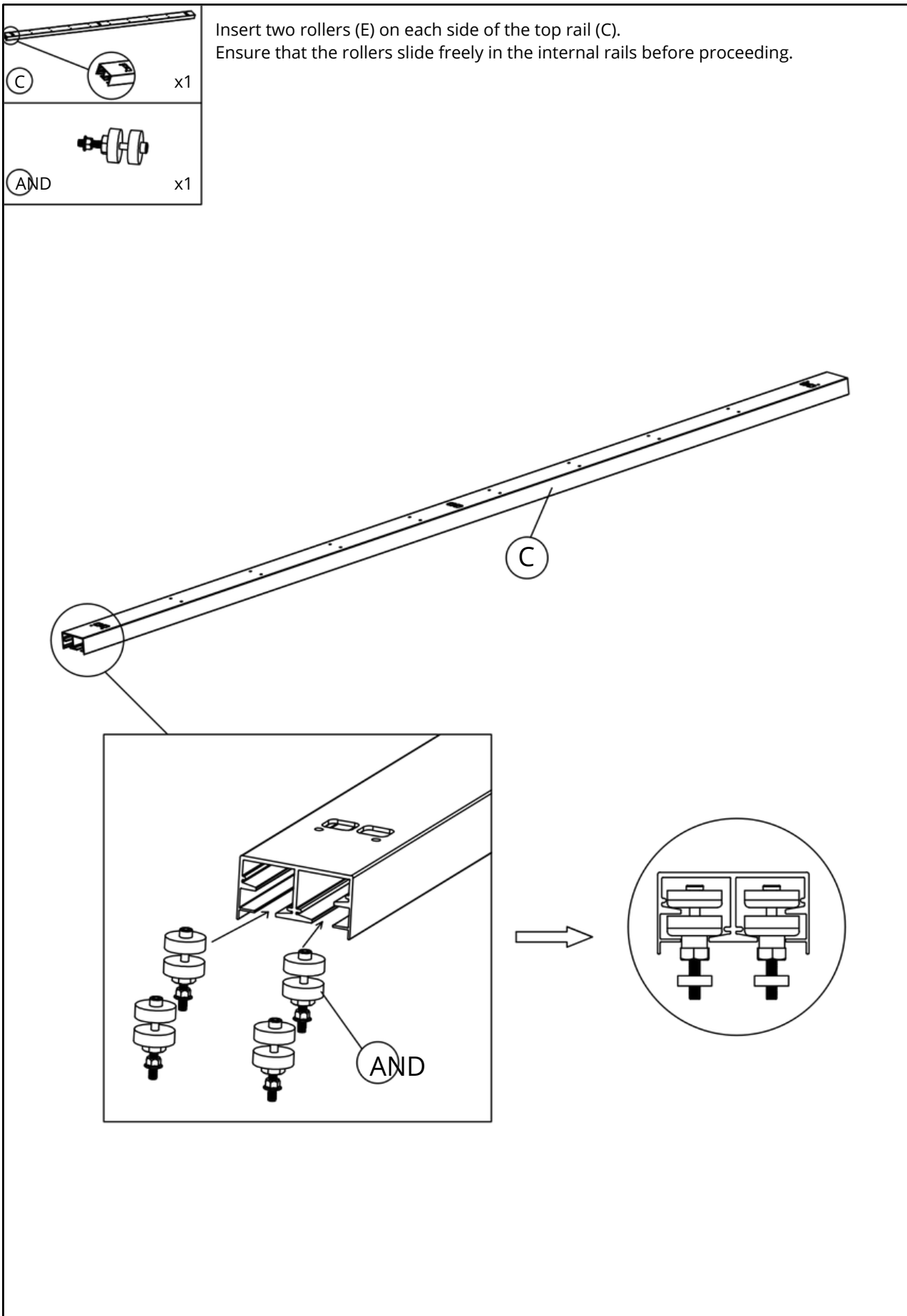

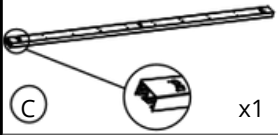

Position the upper rail (C) against the pergola beam.
Check that the rail is perfectly parallel to the outer edge of the beam.
Secure the rail using the self-drilling screws (1) in the designated locations.

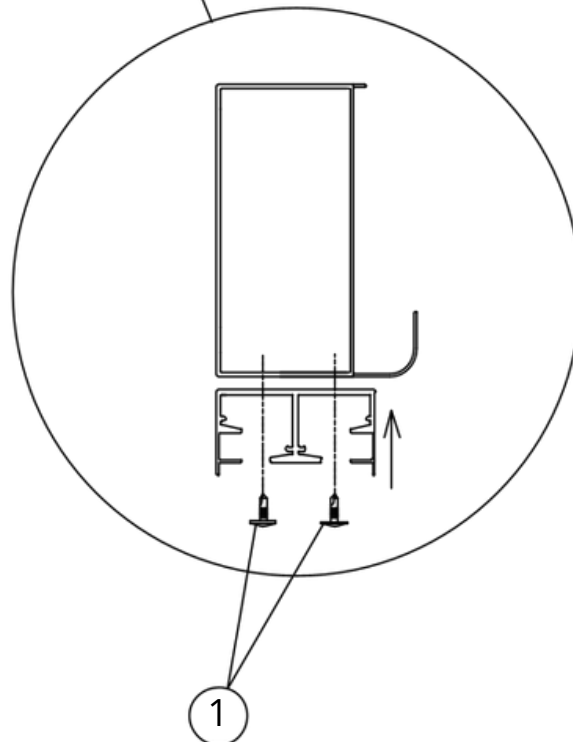
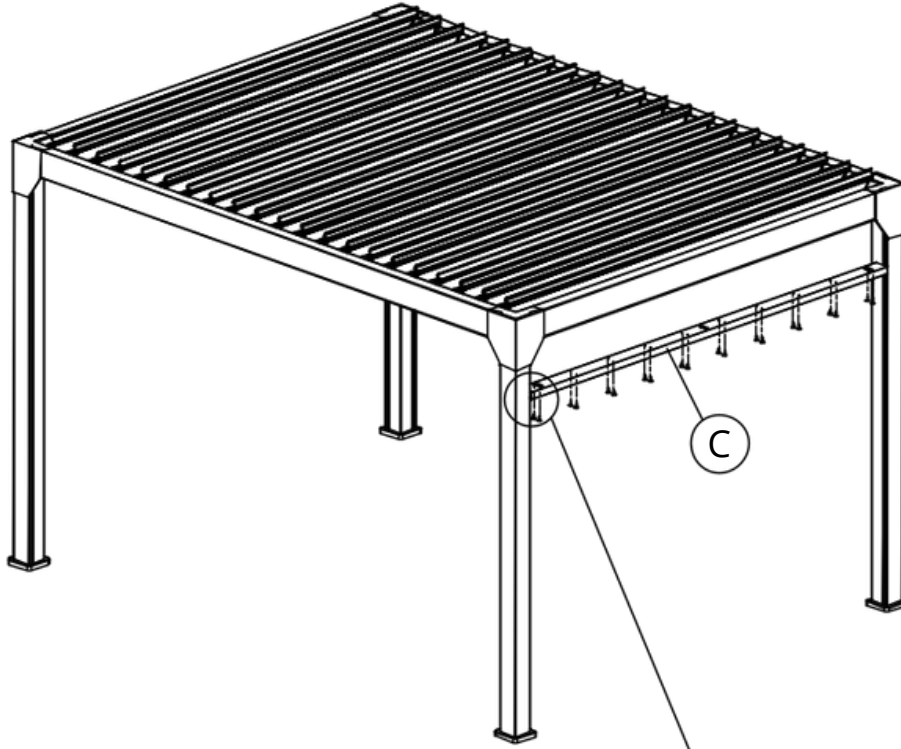

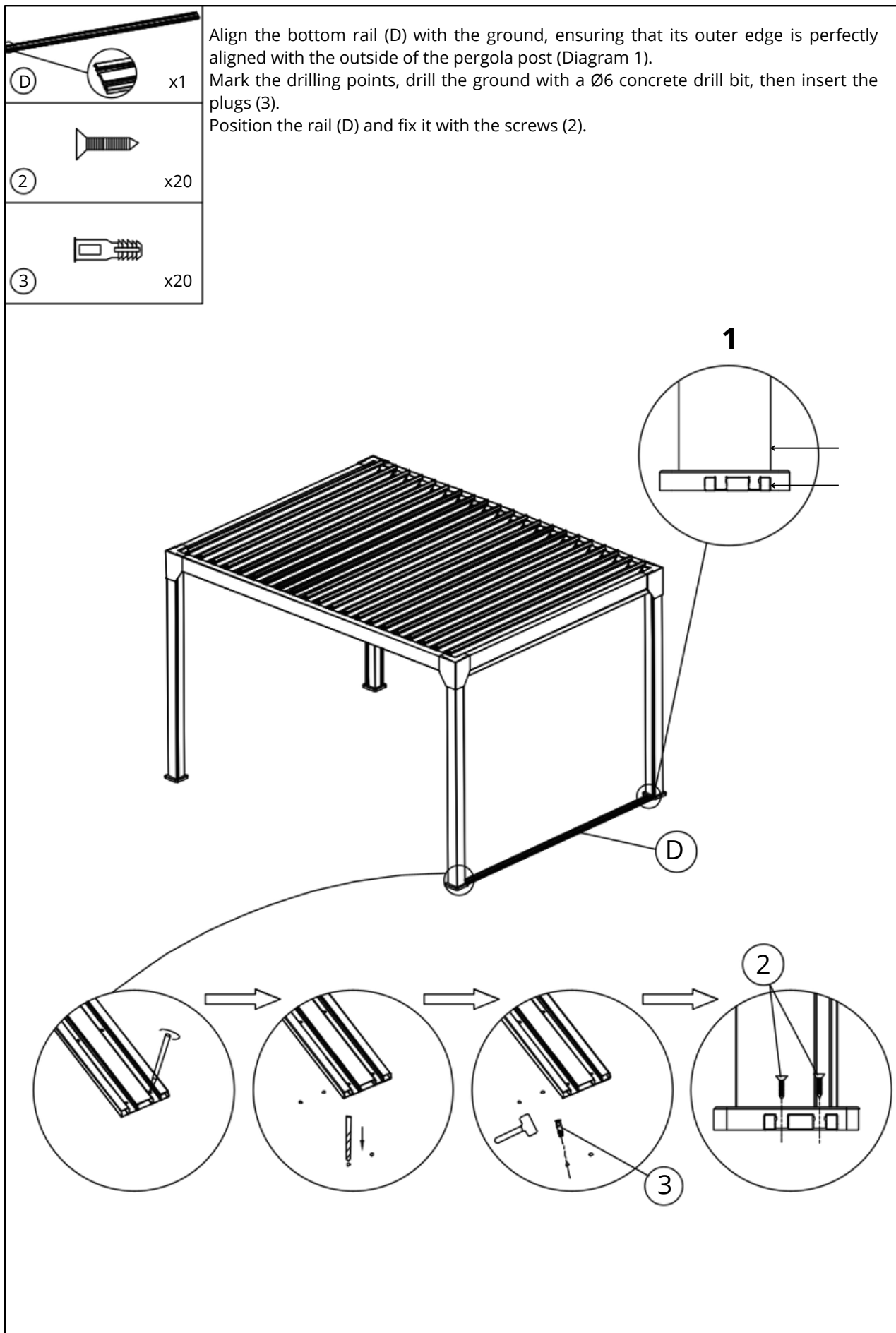

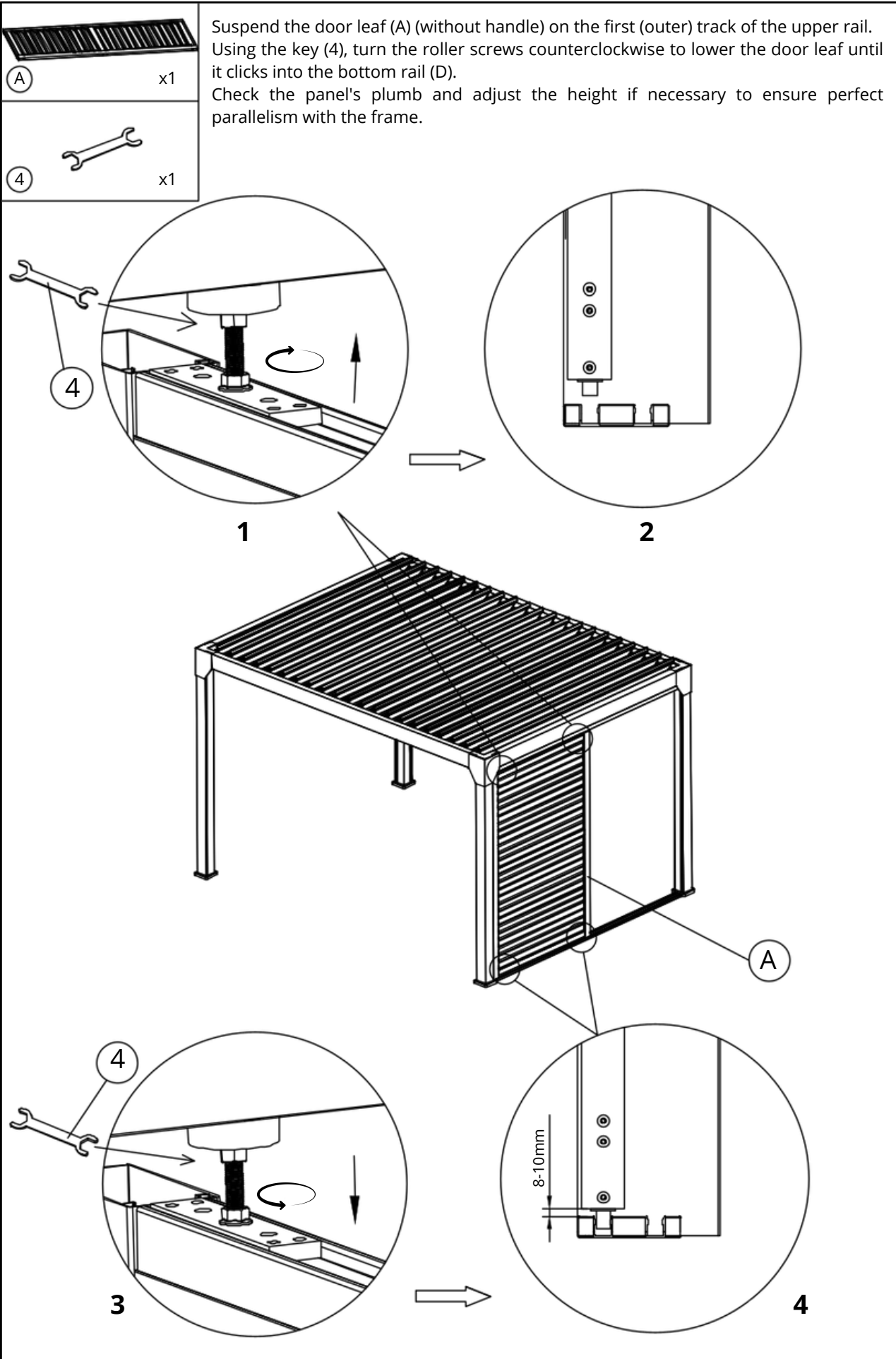

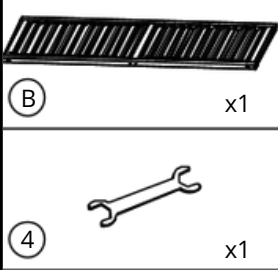

Take the door leaf (B) (with handle) and use the key (4) to screw clockwise to lift the frame.
 Position it so that the lower guide is above the floor rail.
 Then turn counterclockwise to lower the door leaf onto the second track of the lower rail to complete the installation.

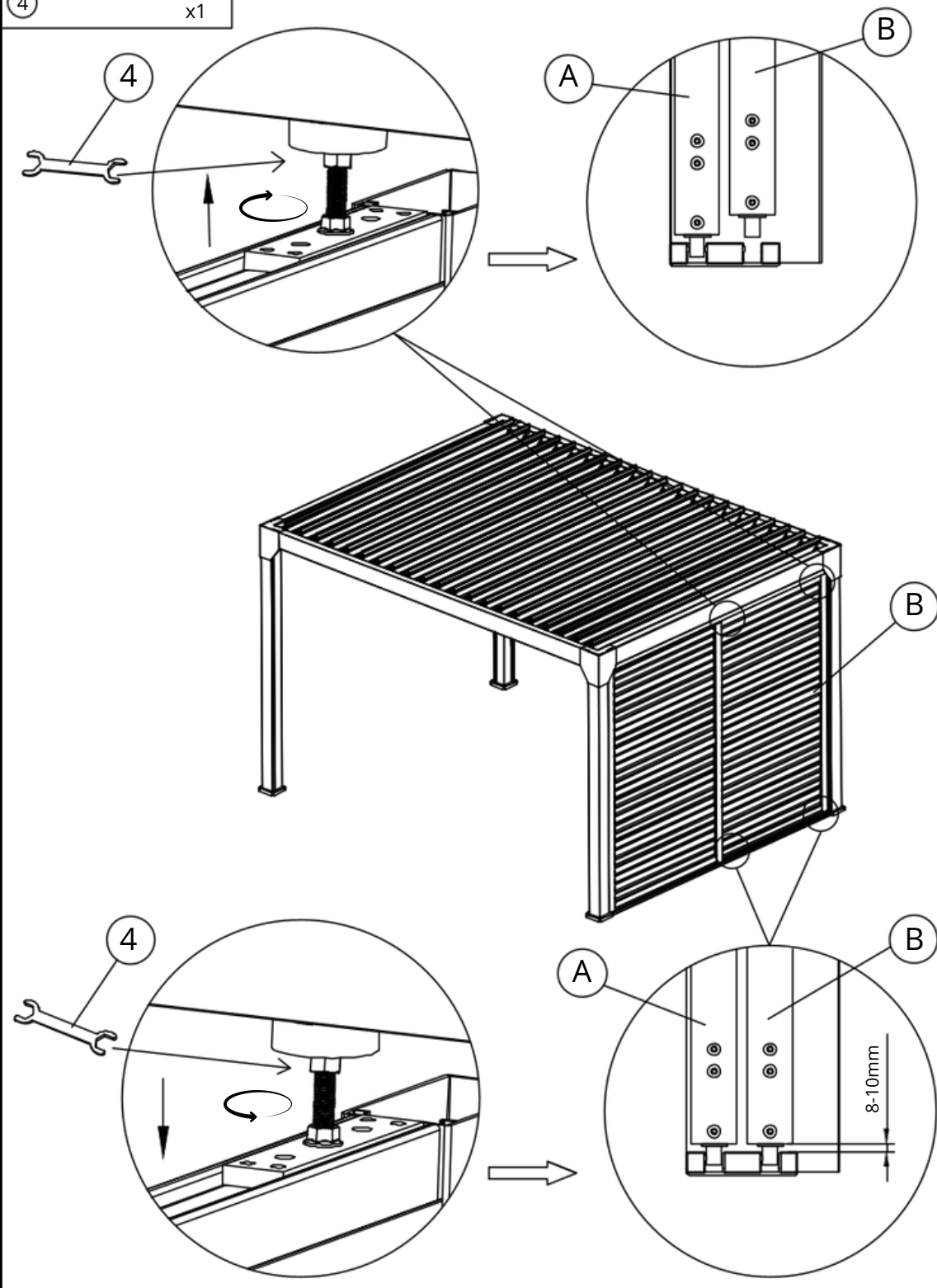

4. Troubleshooting & Frequently Asked Questions

- **Do I need to take any steps before installing my products?**

Installing a bioclimatic pergola, carport or garden shed requires some administrative procedures depending on its dimensions and location.

Our garden sheds have a footprint of 5m² to 20m² and are subject to prior declaration of works. For our models smaller than 5m², you do not need planning permission, but you must still comply with the rules of the Local Urban Development Plan (PLU) or equivalent urban planning document.

Bioclimatic pergolas and carports with a surface area greater than 5m² and less than or equal to 20m² are subject to prior declaration of works.

For bioclimatic pergolas and carports with a surface area greater than 20m², you must submit a building permit application.

Special cases:

- Classified site or protected area: before any installation, it is necessary to obtain the agreement of the Architects of the Buildings of France (ABF).
- Condominium regulations: if you are in a condominium, authorization from the general meeting may be required.
- Local Urban Development Plan (PLU): some municipalities have specific restrictions (height, color, materials). It is advisable to consult the town hall before purchasing a product.

The development tax:

Garden sheds larger than 5m² are subject to the development tax, unless exempted by the municipality. The amount is calculated on a flat-rate basis per m² and varies depending on the location.

- **Can I order the accessories for my bioclimatic pergola at a later date?**

Yes, our bioclimatic pergolas are modular. Various accessories can be added later. Please be careful to check the compatibility of the accessories with your pergola model before placing your order.

- **How does the delivery of my products work?**

Our garden sheds, bioclimatic pergolas, glass walls, mosquito nets, and sunshades are delivered by a carrier. They will contact you to schedule a delivery appointment, which will be made using a semi-trailer equipped with a forklift.

Our curtains are delivered by a traditional carrier.

For a stress-free assembly, find all our assembly instructions in video format on our YouTube page and on our website by clicking on the following link or by scanning the QR code.

<https://www.youtube.com/@greenoutside8067>



<https://green-outside.com/>



5. Warranty and contact

Your product is covered by a legal guarantee against any manufacturing defects. You can find the details of the Green Outside legal guarantee by clicking on the following link.

<https://green-outside.com/procedure-sav/>

or by scanning the QR code



For any warranty claim or in case of a problem with your product, please contact Green Outside customer service using the following contact details:

sav@green-outside.com

04 74 55 36 54 - Option 2

As part of its policy of continuous improvement, Green Outside reserves the right to modify its products without prior notice.

For more information on Green Outside products:
info@green-outside.com and www.green-outside.com