

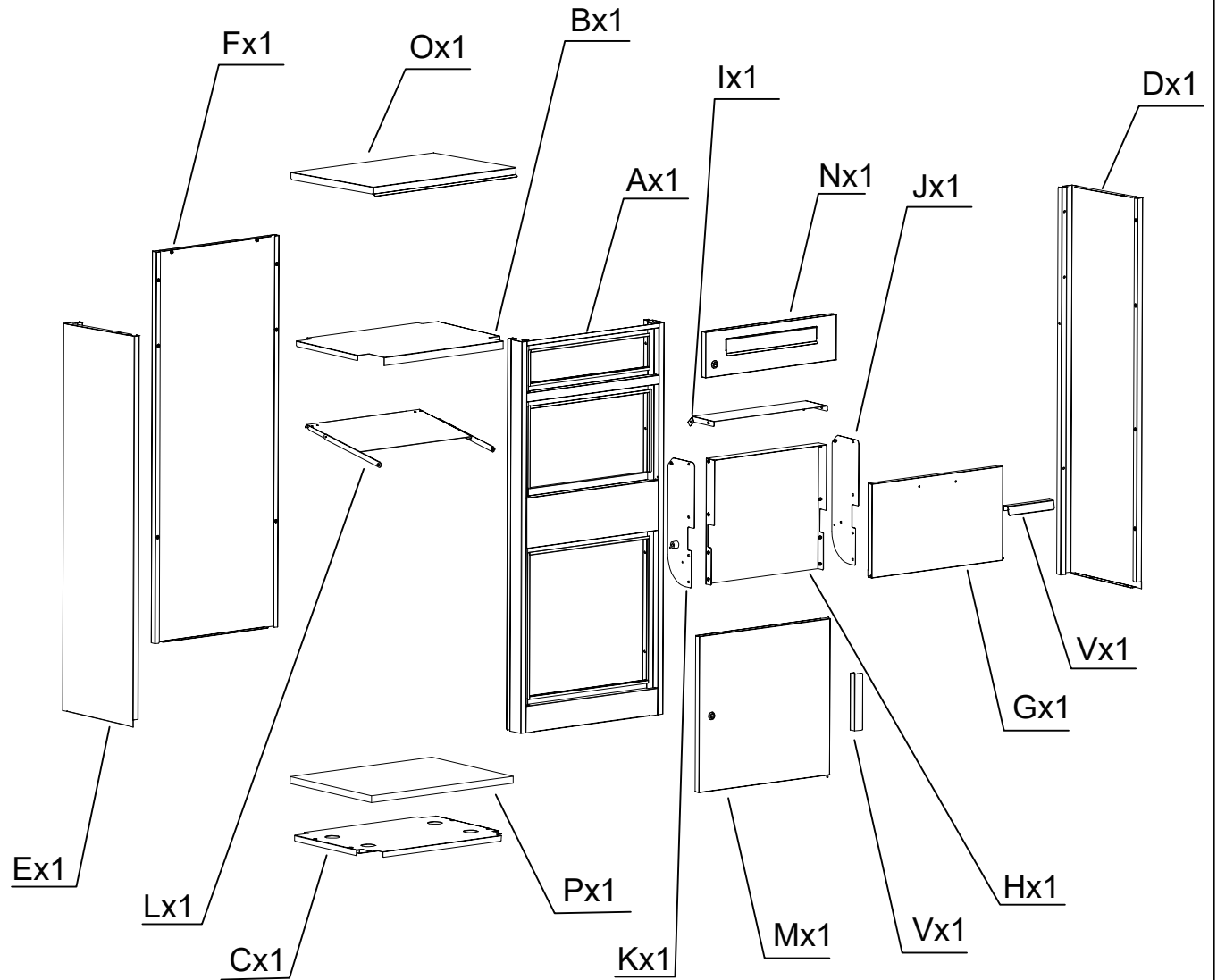

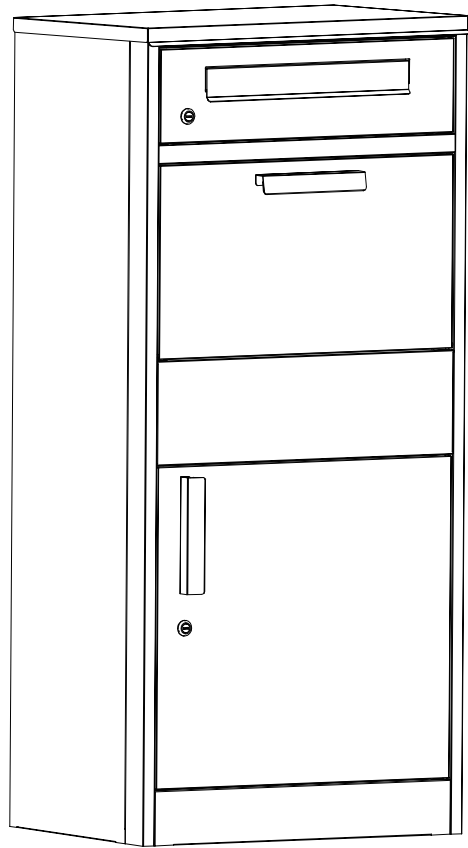







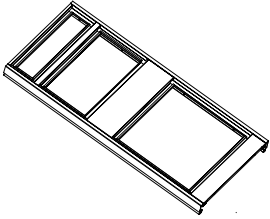
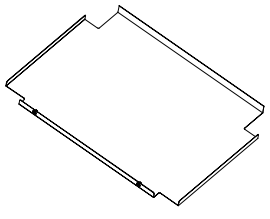
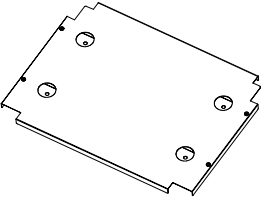
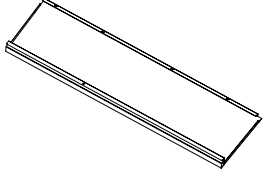
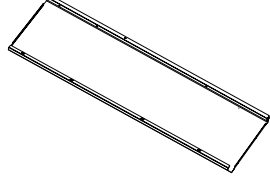
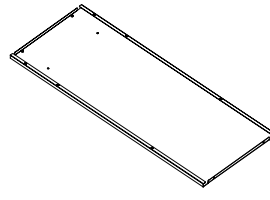
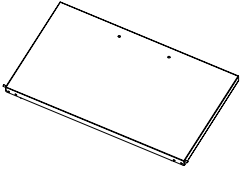
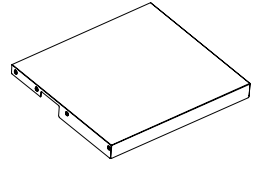
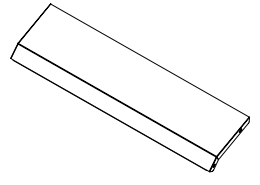
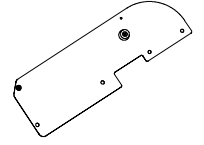
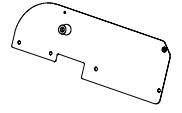
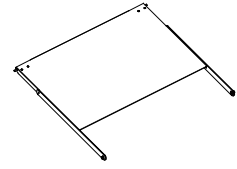
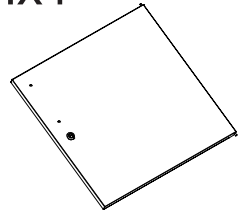
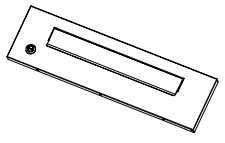
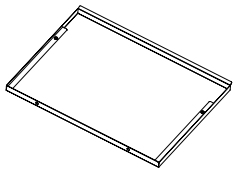
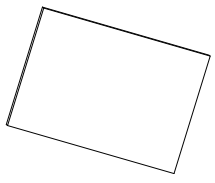
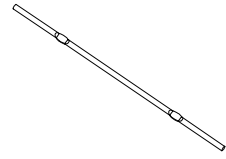

**Handleiding
Manuel
Manual
Anleitung**

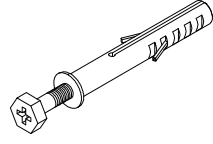
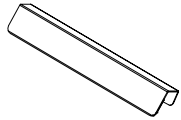
4goodz B.V.
Vendelier 61A 3905 PD Veenendaal Nederland

www.4goodz.nl

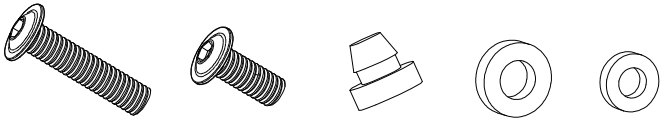

<p>Ax1</p> 	<p>Bx1</p> 	<p>Cx1</p> 	<p>Dx1</p> 	<p>Ex1</p> 	<p>Fx1</p> 
<p>Gx1</p> 	<p>Hx1</p> 	<p>Ix1</p> 	<p>Jx1</p> 	<p>Kx1</p> 	<p>Lx1</p> 
<p>Mx1</p> 	<p>Nx1</p> 	<p>Ox1</p> 	<p>Px1</p> 	<p>Qx1</p> 	<p>Rx32</p>  <p>M4x10mm</p>
<p>Sx4</p>  <p>Ø4.2xØ7*2</p>	<p>Tx4</p>  <p>M4x16mm</p>	<p>Ux4</p> 	<p>Vx2</p> 	<p>Wx4</p>  <p>M4x8mm</p>	<p>Xx2</p>  <p>Ø4.2xØ7*7</p>
<p>Yx4</p>  <p>M4</p>	<p>Zx1</p> 	<p>B1x2</p> 	<p>C1x4</p>  <p>Ø5.2xØ7*2</p>	<p>SPARE PART</p>  <p>X2 X2 X2 X2 X2</p>	

STEP 1

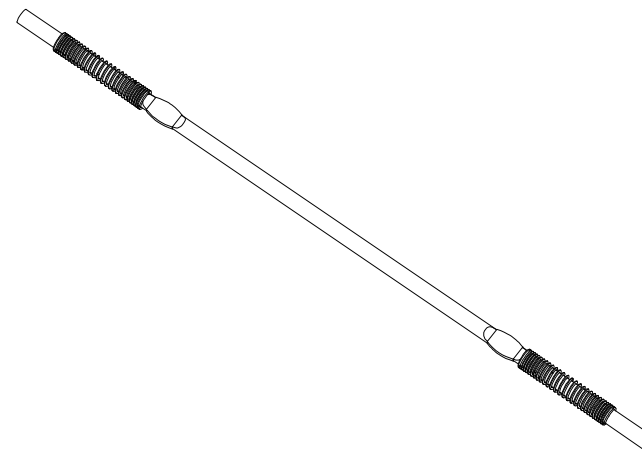
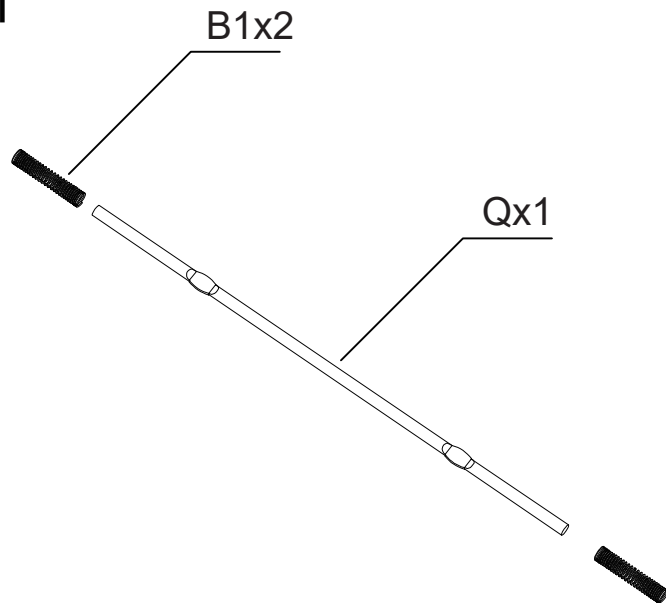

STEP 2

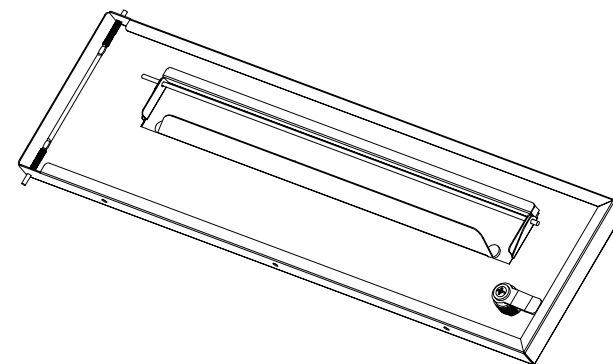
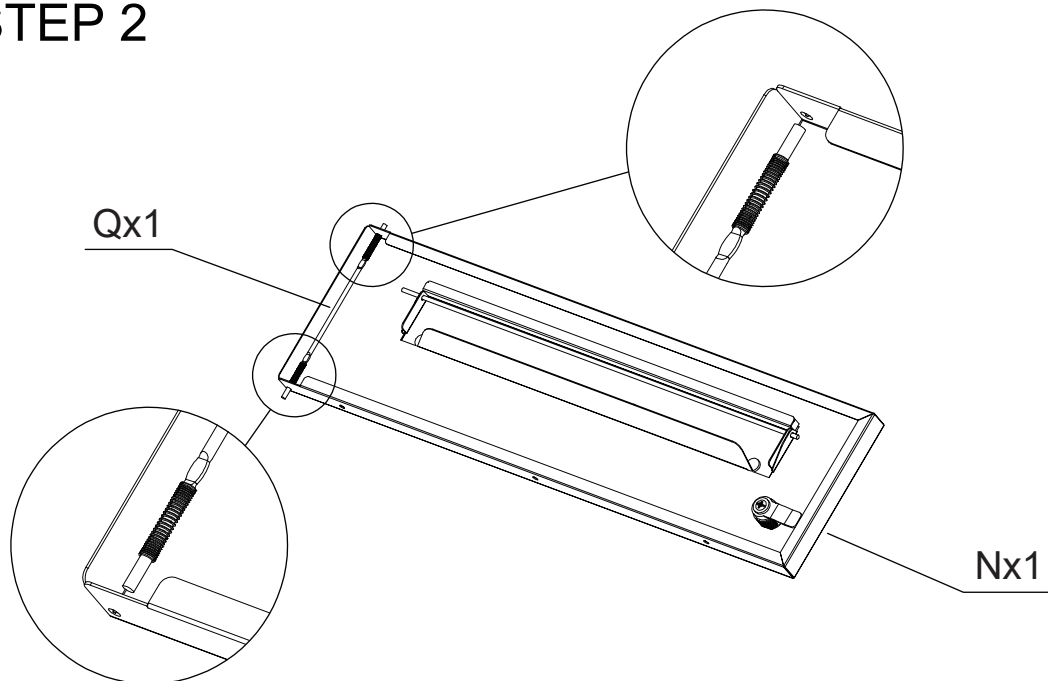

STEP 3

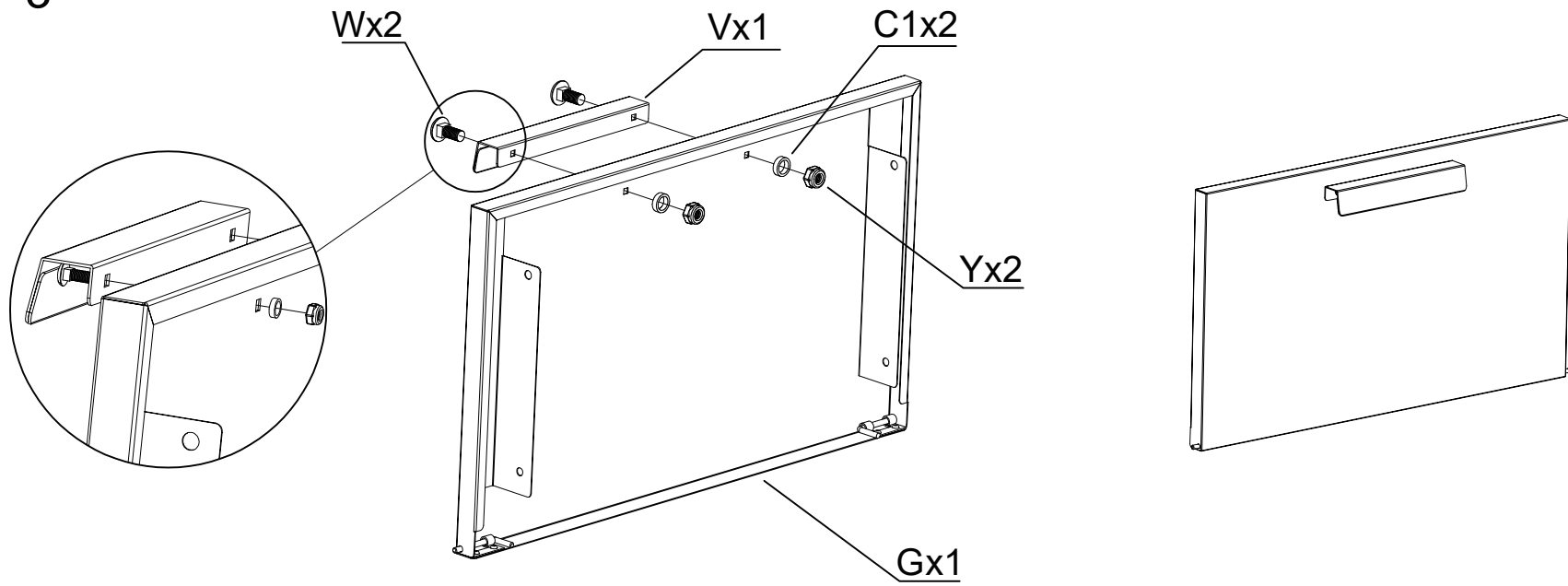

STEP 4

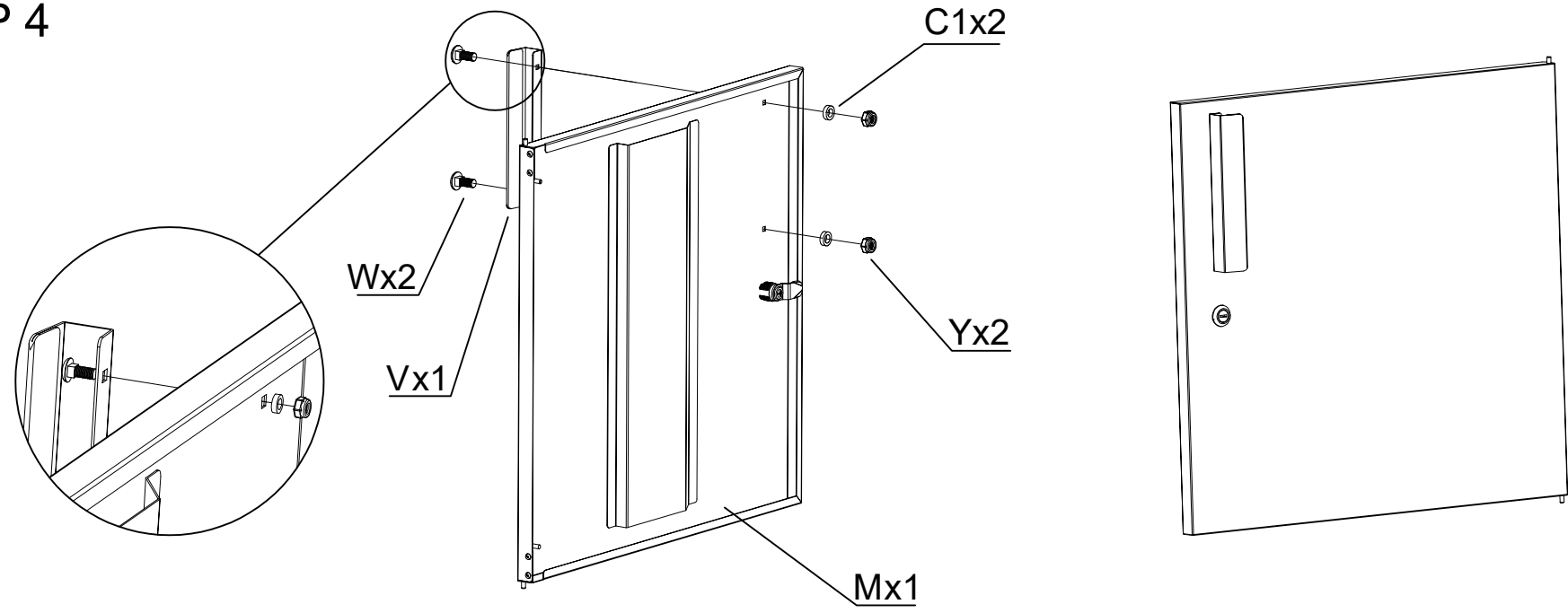

STEP 5

Setzen Sie zunächst alle Schrauben an und drehen Sie sie nur leicht rein. Anschließend können Sie die Schrauben fest ziehen.

Zet eerst alle schroeven erin en draai ze slechts licht vast. Vervolgens kunt u de schroeven stevig aandraaien.

Commencez par mettre en place toutes les vis et ne les serrez que légèrement. Ensuite, vous pourrez serrer les vis fermement.

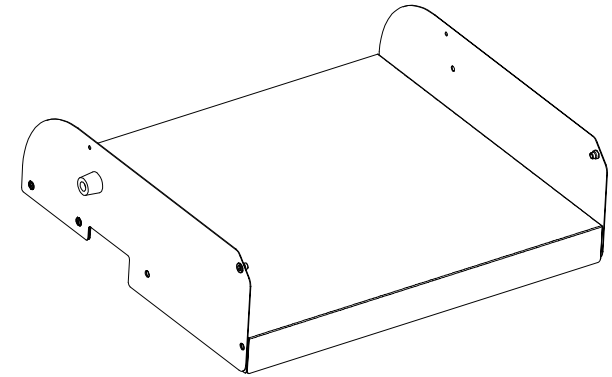
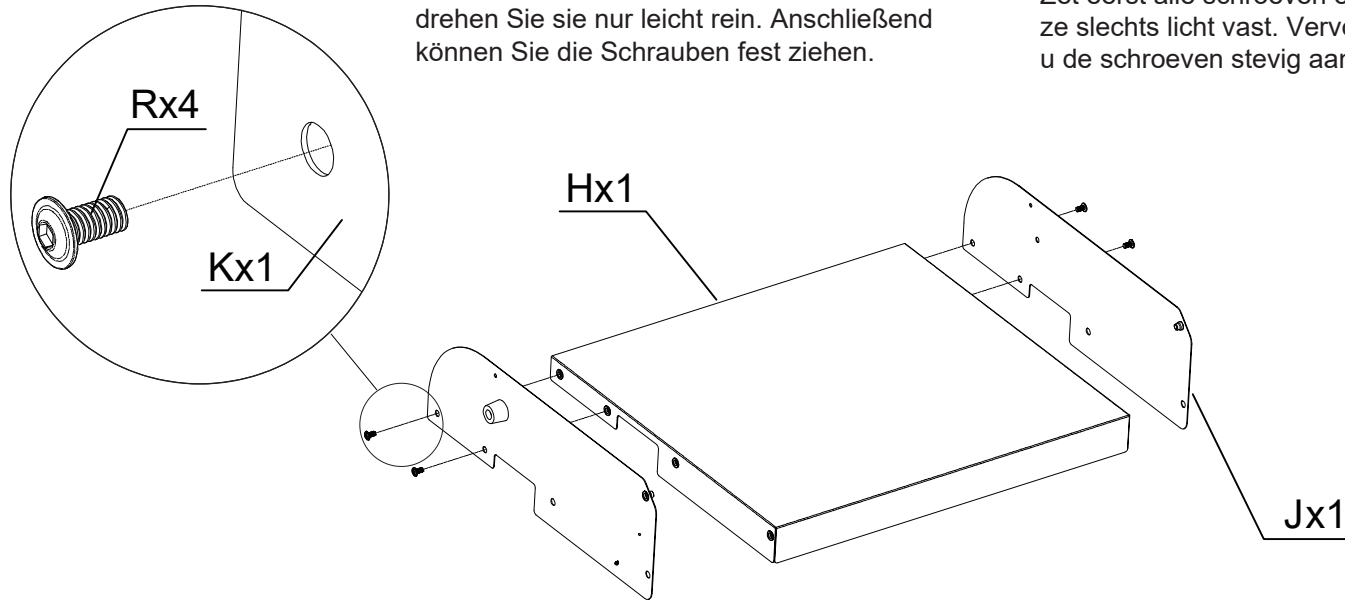

Do not fully tighten the screws at the beginning, so that you can adjust the positions. Only tighten all screws once the assembly is complete.

STEP 6

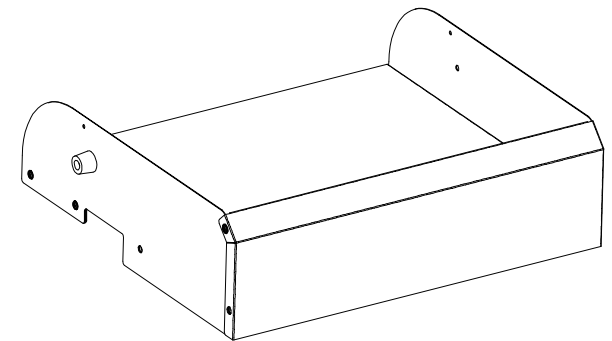
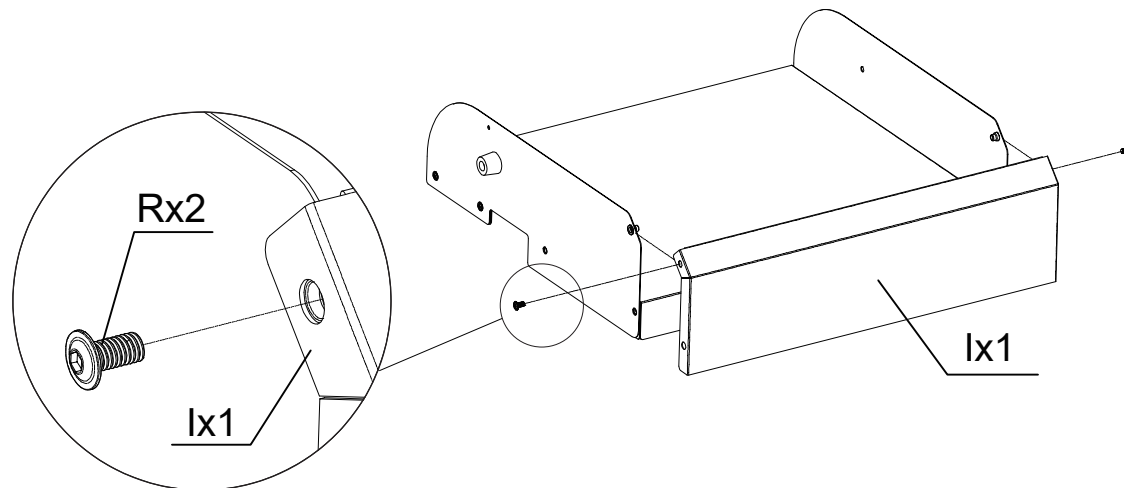

STEP 7

Achten Sie auf die Einbaurichtung

Let op de inbouwrichting.

Faites attention au sens de montage.

Pay attention to the installation direction.

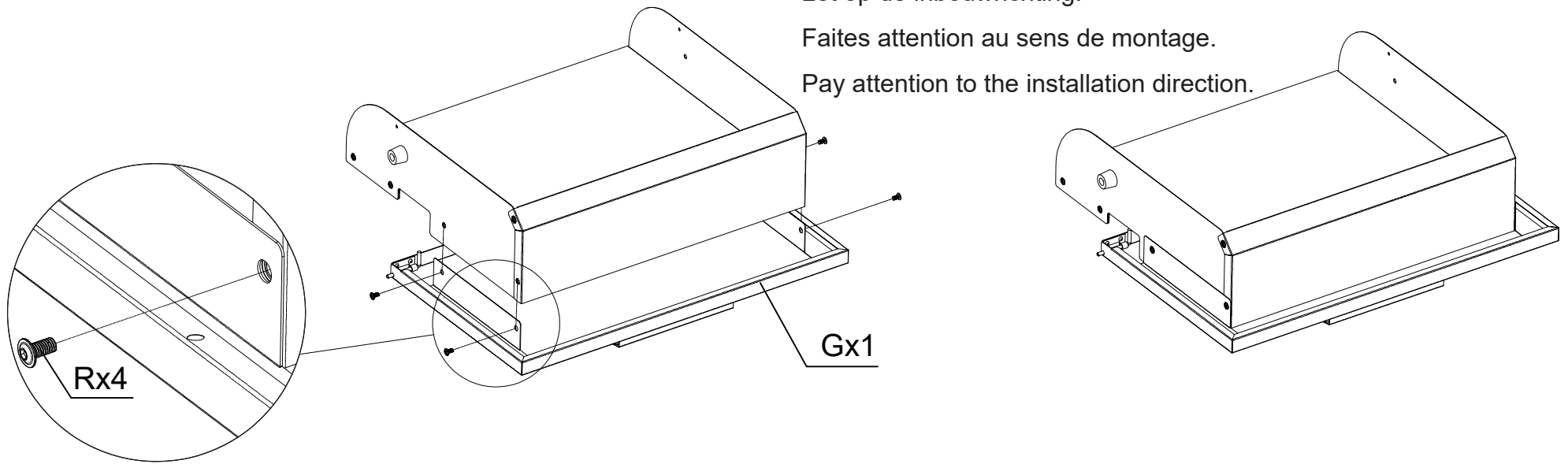

STEP 8

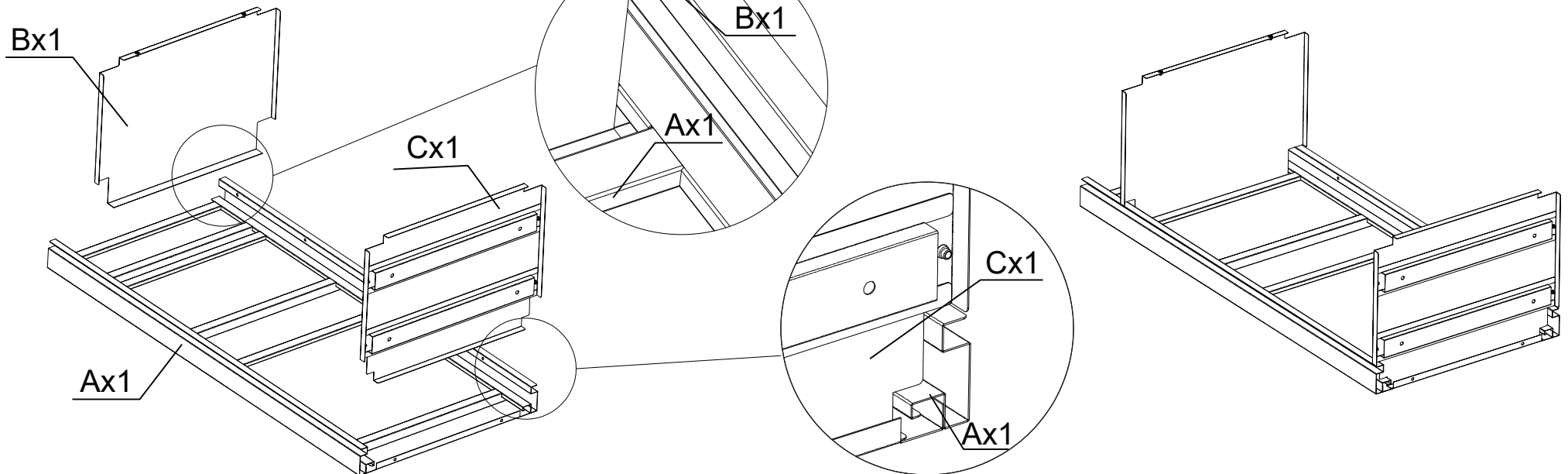

STEP 9

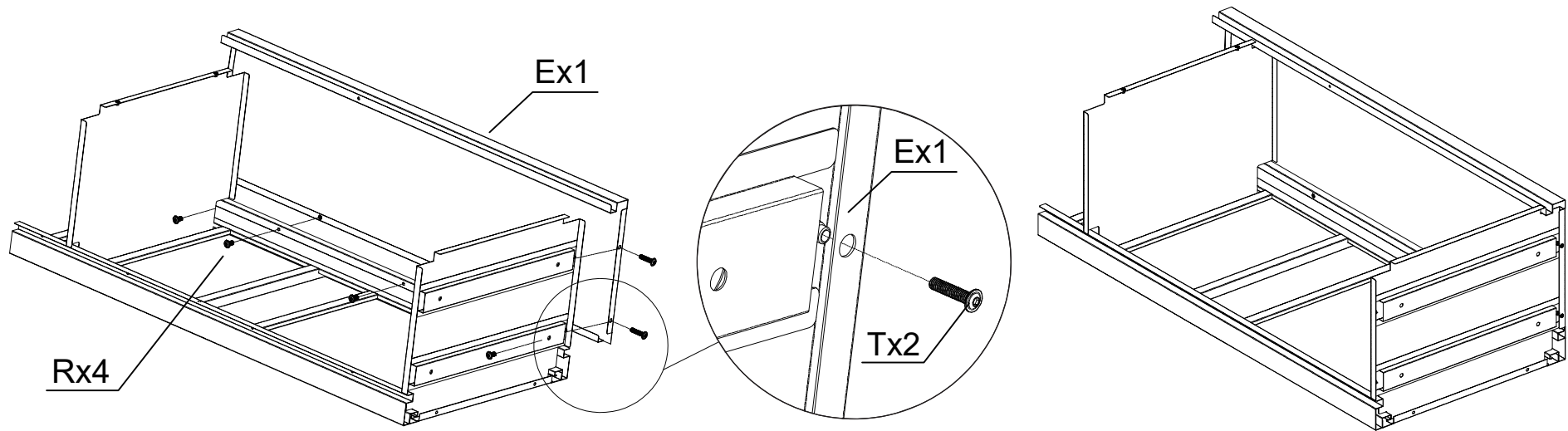

STEP 10

Setzen Sie zunächst alle Schrauben an und drehen Sie sie nur leicht rein. Anschließend können Sie die Schrauben fest ziehen.

Commencez par mettre en place toutes les vis et ne les serrez que légèrement. Ensuite, vous pourrez serrer les vis fermement.

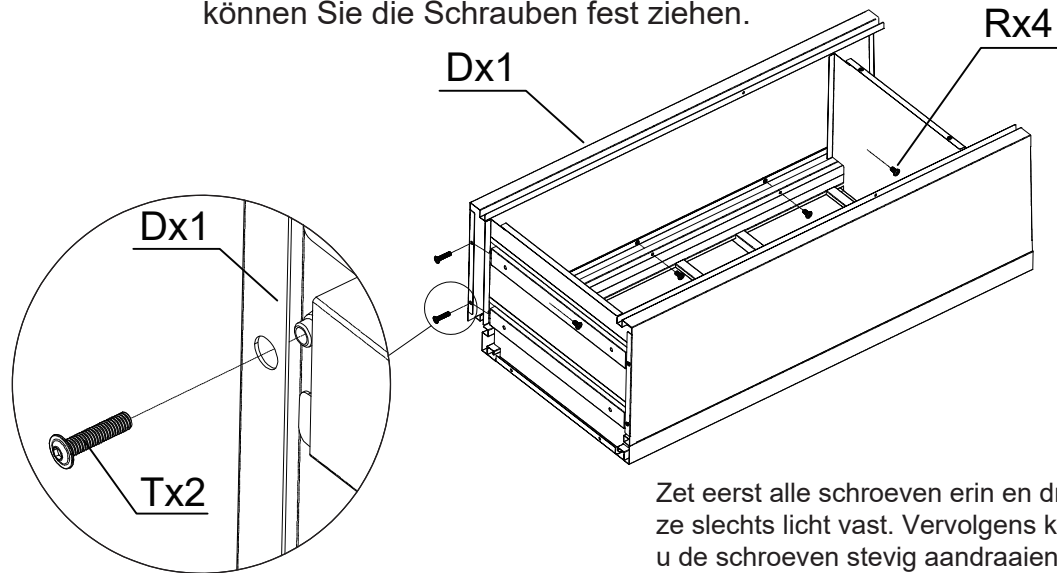

Zet eerst alle schroeven erin en draai ze slechts licht vast. Vervolgens kunt u de schroeven stevig aandraaien.

Do not fully tighten the screws at the beginning, so that you can adjust the positions. Only tighten all screws once the assembly is complete.

STEP 11

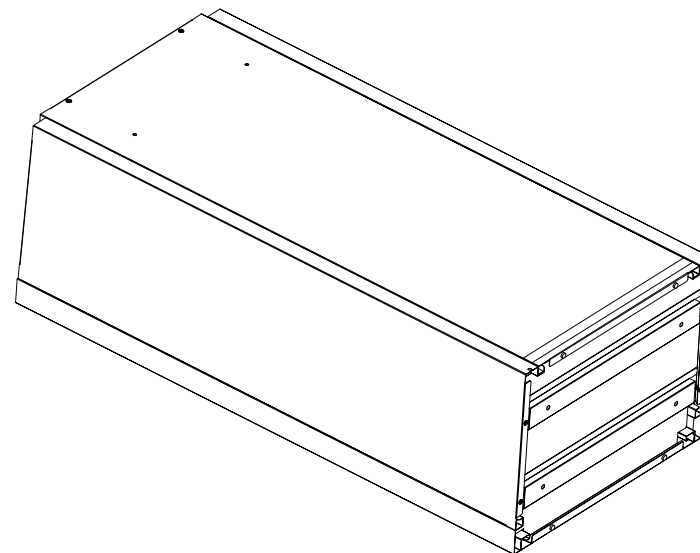
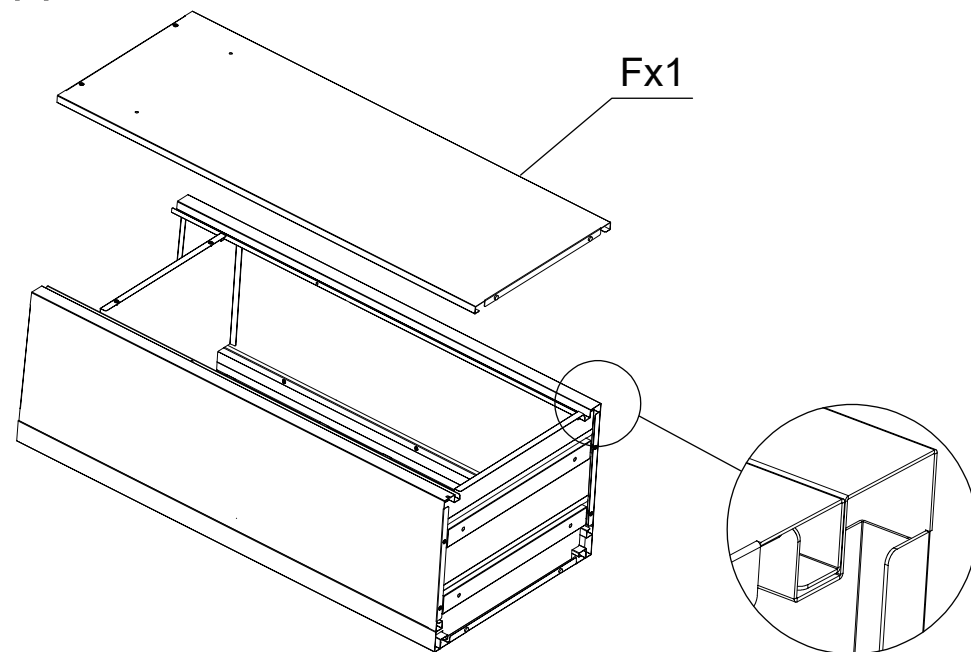

STEP 12

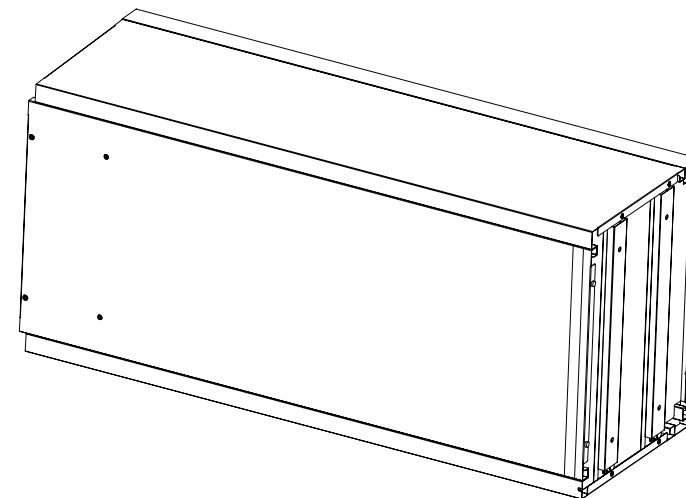
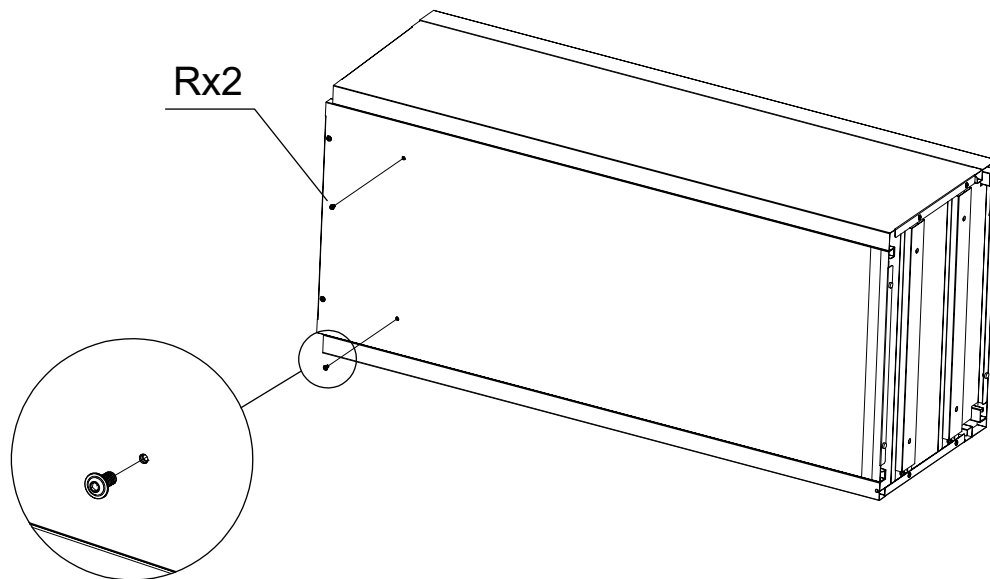

STEP 13

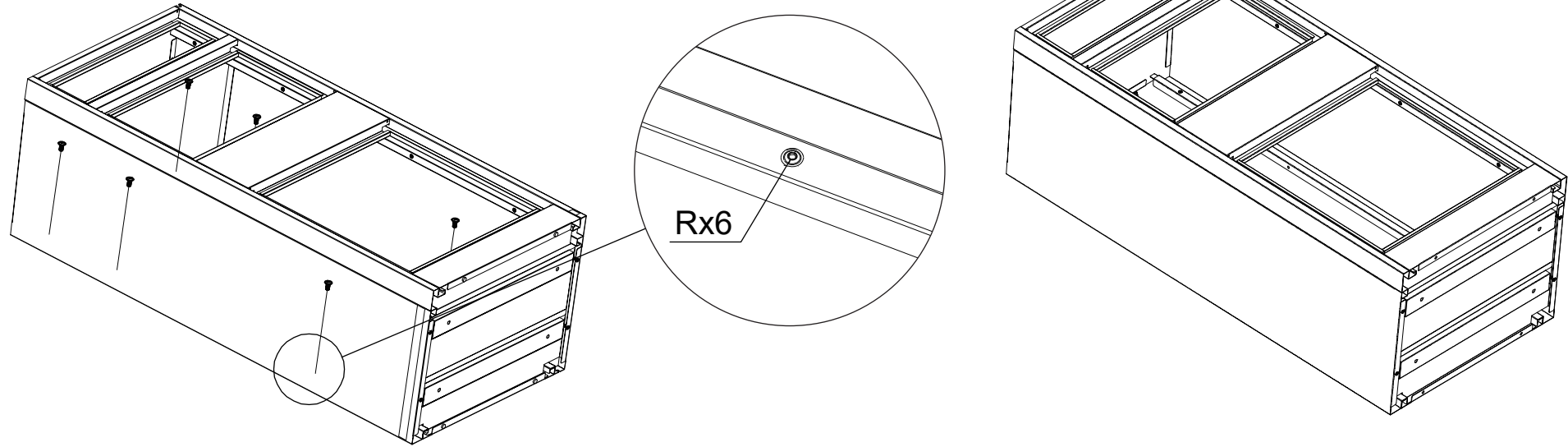

STEP 14

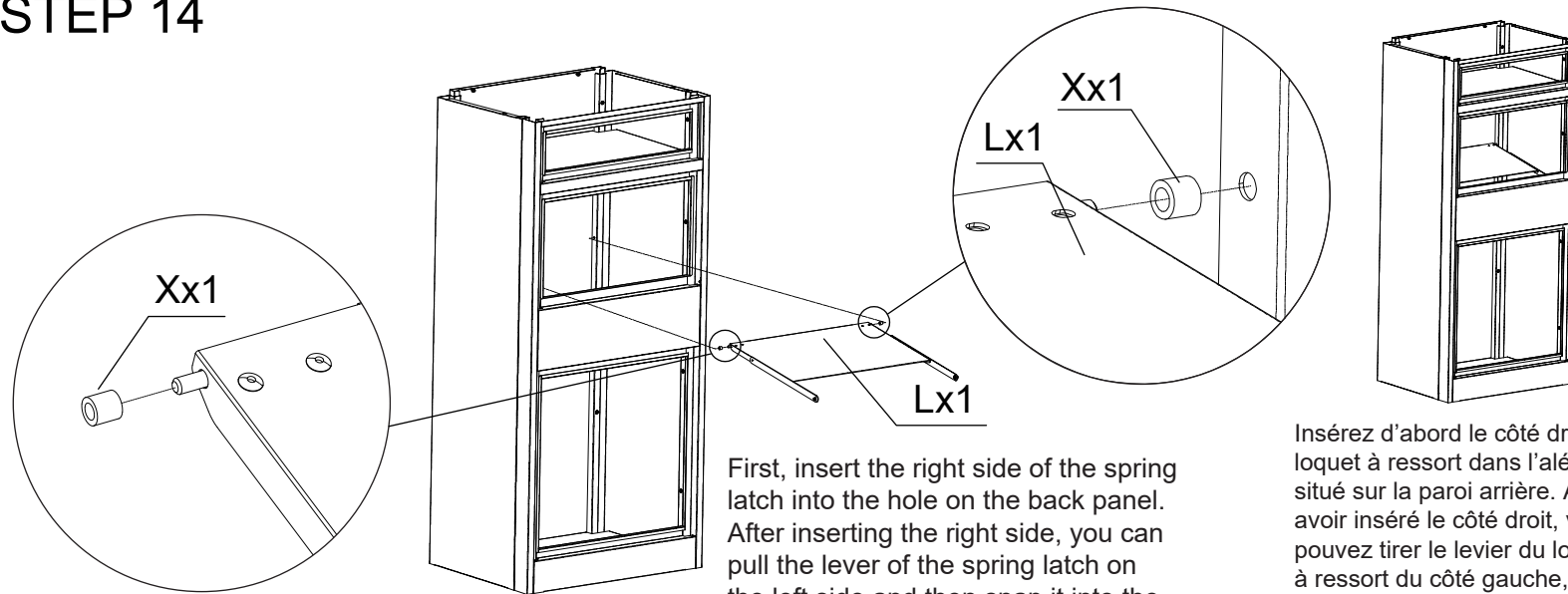

First, insert the right side of the spring latch into the hole on the back panel. After inserting the right side, you can pull the lever of the spring latch on the left side and then snap it into the left hole of the back panel. The assembly is then complete.

Insérez d'abord le côté droit du loquet à ressort dans l'alésage situé sur la paroi arrière. Après avoir inséré le côté droit, vous pouvez tirer le levier du loquet à ressort du côté gauche, puis l'enclencher dans l'alésage gauche de la paroi arrière. Le montage est ainsi terminé..

Setzen Sie zuerst die rechte Seite des Federriegels in die Bohrung an der Rückwand ein. Nach dem Einsetzen der rechten Seite können Sie den Hebel des Federriegels der linken Seite ziehen und danach in die linke Bohrung der Rückwand einrasten lassen. Die Montage ist somit abgeschlossen.

Plaats eerst de rechterkant van de veergrendel in het gat aan de achterwand. Nadat de rechterkant is geplaatst, kunt u de hendel van de veergrendel aan de linkerkant naar buiten trekken en vervolgens in het linker gat van de achterwand laten vastklikken. De montage is daarmee voltooid.

STEP 15

Setzen Sie die zusammengebaute Tür ein, indem Sie zuerst die rechte Seite und dann die linke Seite in Position bringen.

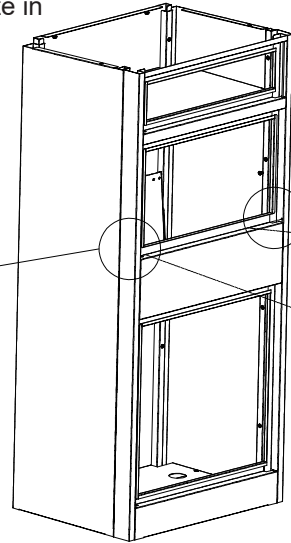
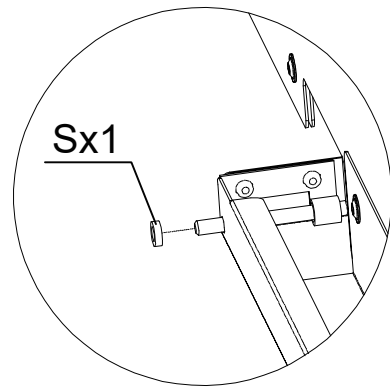

Plaats de gemonteerde deur door eerst de rechterkant en daarna de linkerkant in positie te brengen.

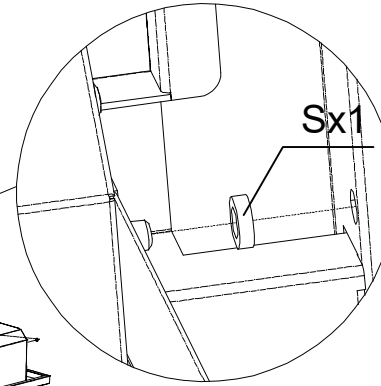

Installez la porte assemblée en positionnant d'abord le côté droit, puis le côté gauche.

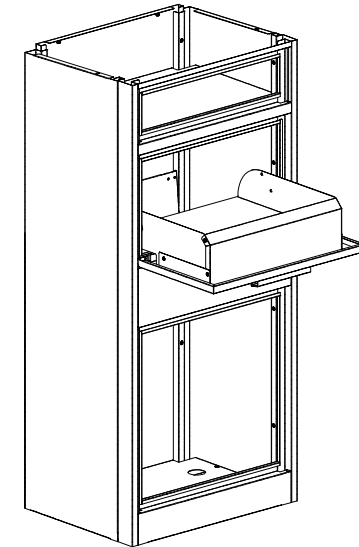

Insert the assembled door by positioning the right side first, then the left side.

STEP 16

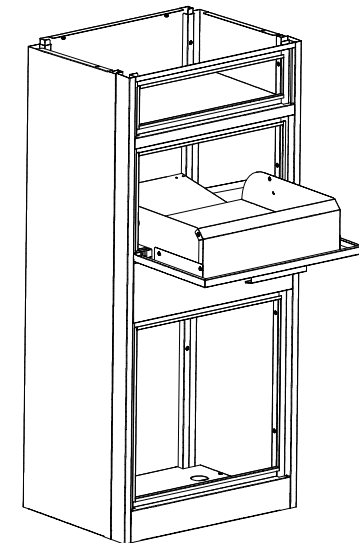
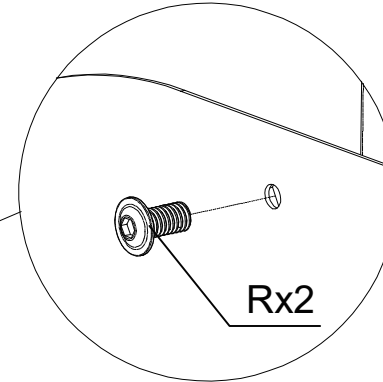
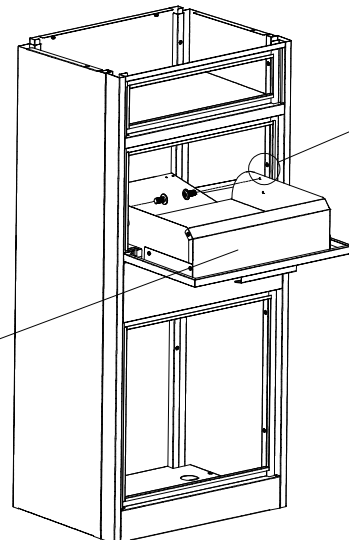
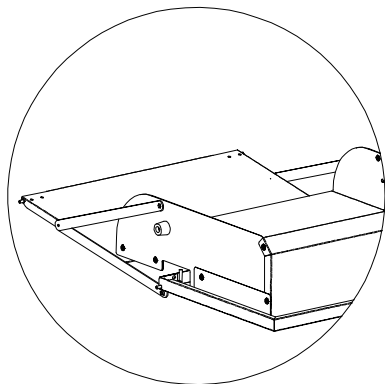

STEP 17

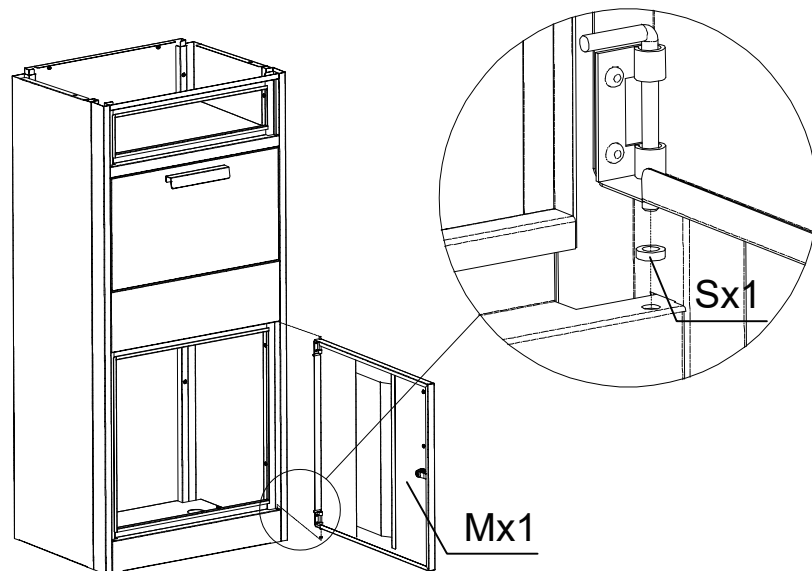

Montieren Sie beim Zusammenbau zuerst die Unterseite und dann die Oberseite.

Monteer bij het assembleren eerst de onderkant en daarna de bovenkant.

Lors de l'assemblage, montez d'abord la partie inférieure puis la partie supérieure.

When assembling, first install the bottom side and then the top side.

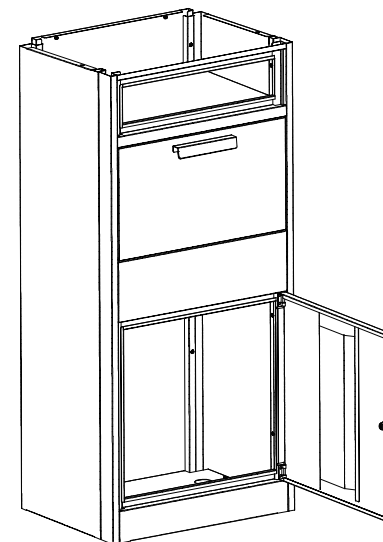

STEP 18

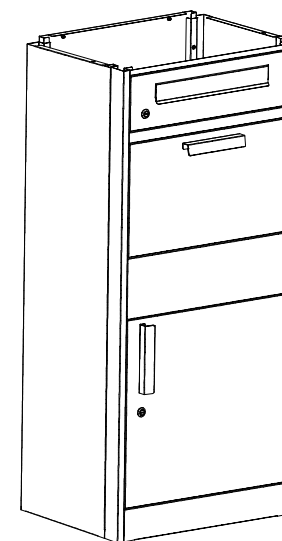
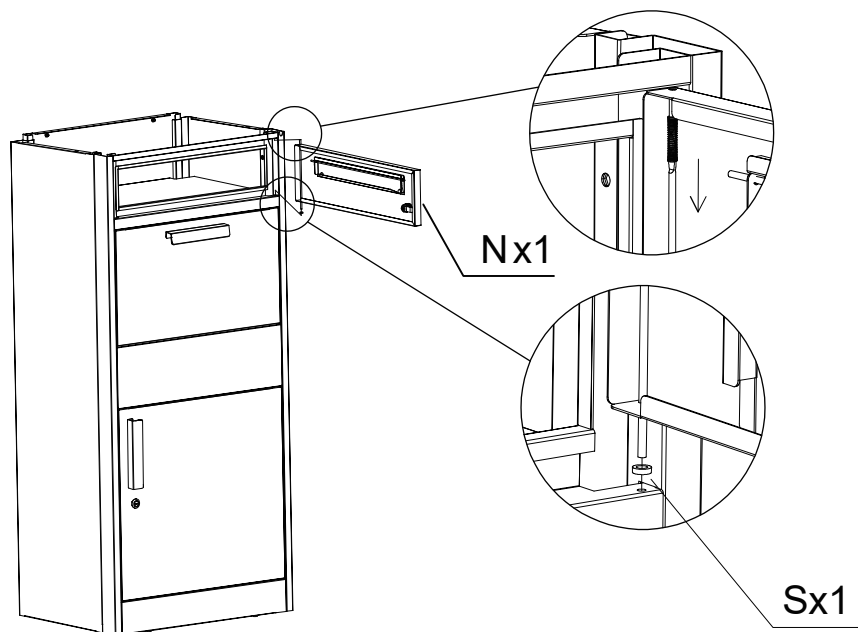

STEP 19

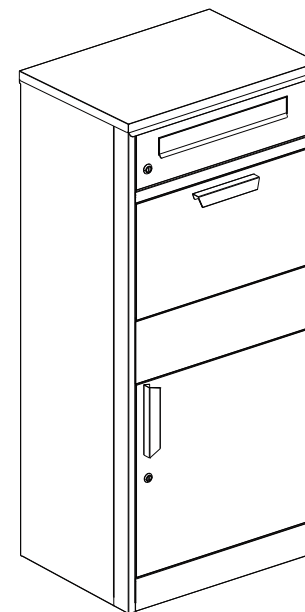
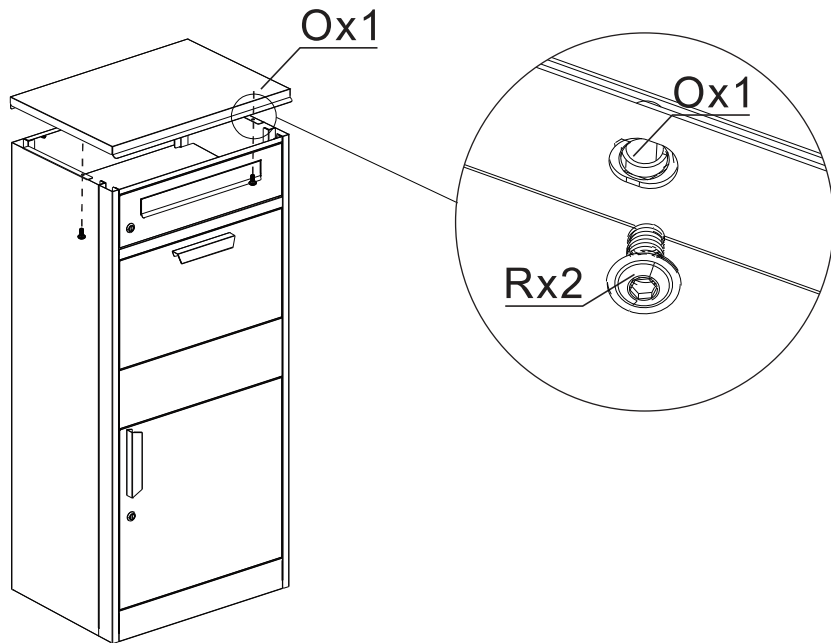

STEP 20

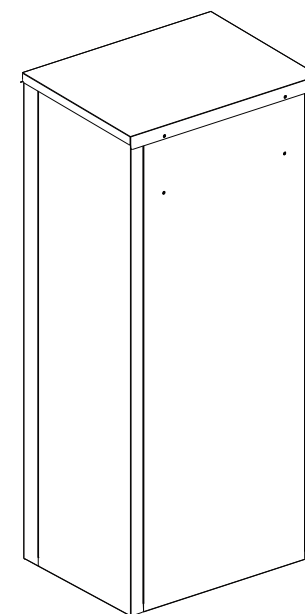
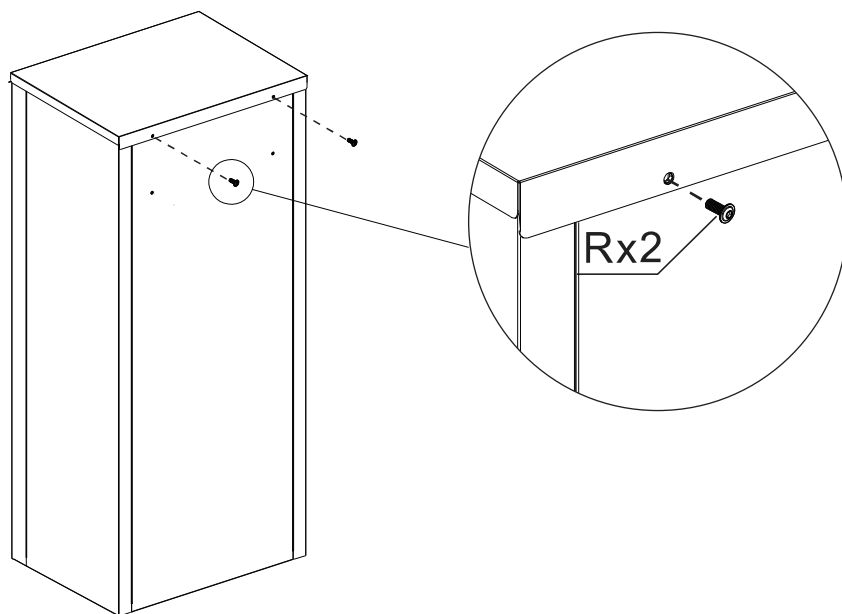

STEP 21

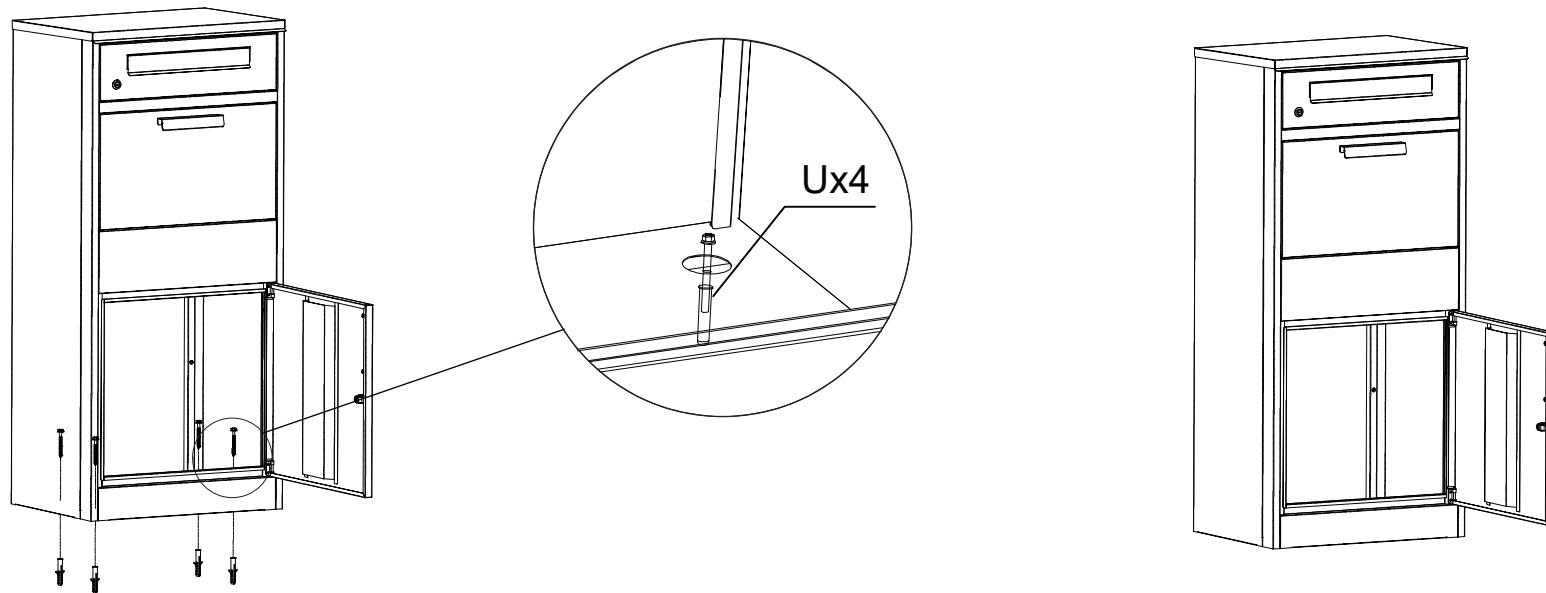

STEP 22

“P” ist eine Schaumstoffmatte, welche die Päckchen vor dem Aufprall schützt.

