

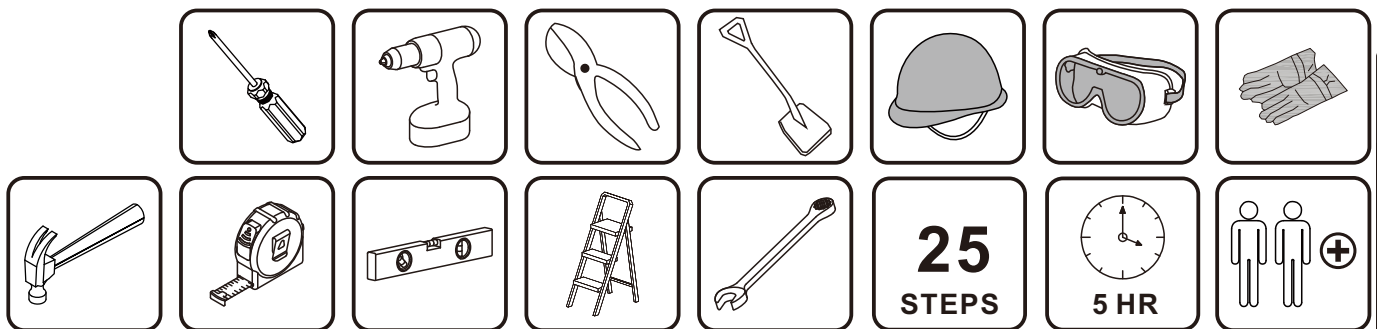

IN251000533V01_GL

84H-458V00

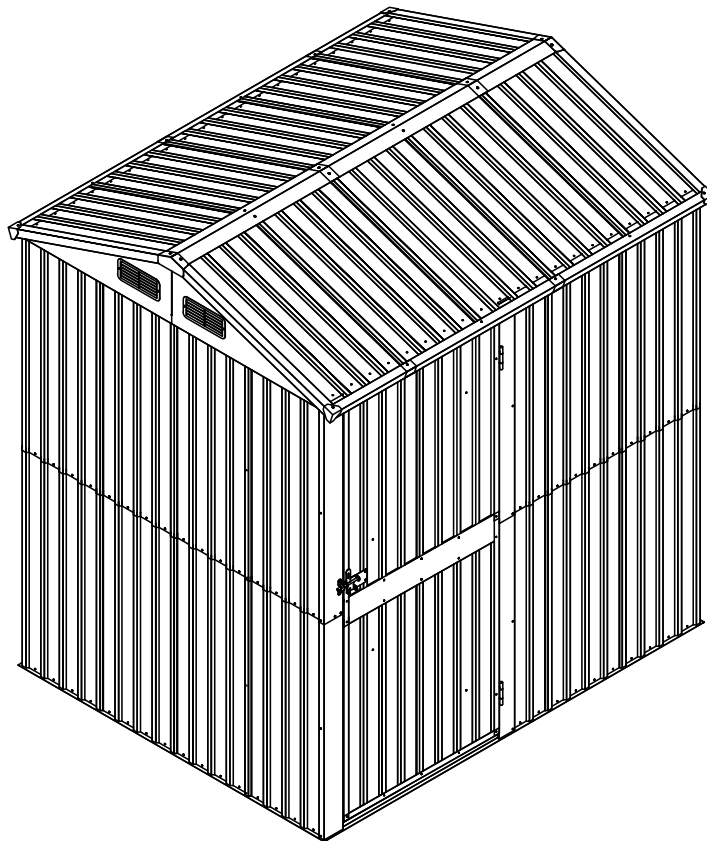

Tools Recommended

EN_IMPORTANT, RETAIN FOR FUTURE REFERENCE: READ CAREFULLY.

FR_IMPORTANT: A LIRE ATTENTIVEMENT ET À CONSERVER POUR CONSULTATION ULTÉRIEURE.

ES_IMPORTANTE, LEA Y GUARDE PARA FUTURAS REFERENCIAS.

PT_IMPORTANTE, RETER PARA REFERÊNCIA FUTURA: LEIA ATENTAMENTE.

DE_WICHTIG! SORGFÄLTIG LESEN UND FÜR SPÄTER NACHSCHLAGEN AUFBEWAHREN.

IT_IMPORTANTE! CONSERVARE IL PRESENTE MANUALE PER FUTURO RIFERIMENTO E LEGGERLO ATTENTAMENTE.

ASSEMBLY PREPARATION

Please check local building codes regarding footings, location and other requirements before beginning construction. Study and understand this owner's manual of important information and helpful tips for easier and more enjoyable assembly.

Assembly instructions:

Reviewing all instructions and the appropriate information before you begin, make sure following the step sequence carefully for successful results.

Flooring base:

The site must be prepared so that the base of the shed is level all round and checking with a spirit level is required.

The base can be constructed by treated timber or concrete, in order to stop the moisture getting into the shed, The shed is not designed to be built onto lawn directly. Also the ground will get muddy during rainy days.

If a concrete pad is made, it is important that this slopes towards the edges to prevent water ingress. Time must be allowed for any concrete or cement to dry before building the shed on top.

Bases can also be constructed from bricks, blocks, or mounted on a concrete pad.

The bricks or blocks should be cemented onto firm and level concrete footings and the greenhouse frame drilled and screwed to the base.

Parts and Parts List:

Before you start, separate and identify all the parts and hardware to be sure that you have all the necessary parts for your building (refer to the Parts List Page).

Do not attempt to assemble the building if parts are missing because any building left partially assembled may be seriously damaged by light winds.

Safety must be put in the No. 1 position:

- 1 Select a dry and calm day for your assembly. Team works (Two or more people) are required during the assembly;
- 2 Wearing safety gloves, eye protection and long sleeves during the assembly to prevent injury; Pay attention to the sharp edge of some parts;
- 3 Children and pets are not allowed entering into the construction site;
- 4 Never concentrate your total weight on the roof of the building. When using a step ladder make sure that it is safety;

Care & Maintenance:

- 1 Keep the shed clean with soft cloth, use water if necessary;
- 2 Keep the door tracks clear of dirt and other stuff that prevent them from sliding easily.
- 3 Clean the snow with necessary tools to make sure it is safe to enter into; Heavy snow may cause collapse, please make sure safety before entering into.
- 4 The shed is not made for living but storing stuff.

PRÉPARATION DE L'ASSEMBLAGE

Veillez vérifier les codes du bâtiment locaux concernant les semelles, l'emplacement et d'autres exigences avant de commencer la construction. Étudiez et comprenez dans ce manuel d'information les informations importantes et les conseils utiles pour un montage plus facile et plus agréable.

Instructions de montage :

Avant de commencer, passez en revue toutes les instructions et les informations appropriées. Assurez-vous de suivre attentivement la séquence des étapes pour obtenir des résultats satisfaisants.

Base de plancher :

Le site doit être préparé de sorte que la base du hangar est de niveau sur le tout pourtour, et il faut vérifier avec un niveau à bulle.

La base peut être construite par du bois traité ou du béton, afin d'empêcher l'humidité de pénétrer dans le hangar. **Le hangar n'est pas conçu pour être construit directement sur la pelouse.** Aussi le sol sera boueux pendant les jours de pluie.

Si un tampon en béton est fait, il est important que celle-ci soit inclinée vers les bords pour empêcher l'eau de pénétrer.

Le temps doit être autorisé pour tout béton ou ciment à sécher avant de construire le hangar sur le dessus.

La base peut également être construite à partir de briques, de blocs ou montées sur un socle en béton.

Les briques ou les blocs doivent être cimentés sur des semelles en béton fermes et de niveau et le cadre de serre drillé et vissé à la base.

Pièces et liste des pièces :

Avant de commencer, séparez et identifiez toutes les pièces et le matériel pour vous assurer que vous avez toutes les pièces nécessaires pour votre bâtiment (voir la page Liste des pièces).

N'essayez pas d'assembler le bâtiment si des pièces manquent, car tout bâtiment laissé partiellement assemblé peut être gravement endommagé par de légers vents.

La sécurité doit être votre préoccupation no.1 :

1. Sélectionnez un jour sec et calme pour votre assemblée. Le travail en équipe (deux personnes ou plus) est requis pendant le montage.

2. Porter des gants de protection, des lunettes de protection et des manches longues pendant le montage pour éviter les blessures ; Faites attention au bord tranchant de certaines parties ;

3. Les enfants et les animaux domestiques ne sont pas admis sur le chantier de construction.

4. Ne concentrez jamais votre poids total sur le toit du bâtiment. Lorsque vous utilisez un escabeau, assurez-vous qu'il est en sécurité.

Entretien et maintenance :

1. Gardez la remise propre avec un chiffon doux, utilisez de l'eau si nécessaire ;

2. Gardez les rails de la porte exempts de saleté et autres objets qui les empêchent de glisser facilement.

3. Nettoyer la neige avec les outils nécessaires pour s'assurer qu'il est sans danger d'entrer ; Une neige abondante peut provoquer un effondrement, assurez-vous de la sécurité avant d'entrer.

4. La remise n'est pas faite pour soulever mais pour ranger des objets.

PREPARACIÓN DEL MONTAJE

Antes de comenzar la construcción, consulte los códigos de construcción locales con respecto a las bases, la ubicación y otros requisitos. Estudie y comprenda este manual del propietario ya que contiene información importante y consejos útiles para un montaje más fácil y agradable.

Instrucciones de montaje

Revise todas las instrucciones y la información apropiada antes de comenzar, asegúrese de seguir cuidadosamente la secuencia de pasos para obtener resultados exitosos.

Base de suelo:

El sitio para realizar la instalación debe estar preparado para que la base del cobertizo esté nivelada y se requiera verificar con un nivel de burbuja.

Para evitar que la humedad penetre en el cobertizo, la base se puede construir con madera tratada u hormigón. **El cobertizo no está diseñado para ser construido directamente sobre el césped.** Además, el suelo se enlodará durante los días lluviosos.

Si hace una plataforma de hormigón, es importante que las pendientes inclinen hacia los bordes para evitar la entrada de agua.

Debe esperar para que la plataforma de hormigón, concreto o cemento se seque antes de construir el cobertizo en sobre la plataforma.

Las bases también pueden ser construidas con ladrillos, bloques o montarse sobre una plataforma de hormigón.

Los ladrillos o bloques deben ser cementados sobre las bases de concreto firmes y niveladas y el marco del invernadero debe ser perforado y atornillado a la base.

Lista de Piezas y Accesorios:

Antes de comenzar, separe e identifique todas las piezas y el hardware para asegurarse de que tiene todas las piezas necesarias para su cobertizo (consulte la página de Lista de Piezas).

No intente ensamblar el cobertizo si faltan piezas, porque cualquier cobertizo parcialmente ensamblado puede resultar seriamente dañado por vientos ligeros.

La seguridad se debe enfocar en la posición No. 1.

- 1 Seleccione un día seco y tranquilo para su montaje. Se requiere trabajo en equipo (dos o más personas) durante el montaje.
- 2 Use guantes de seguridad, protección ocular y mangas largas durante el montaje para evitar lesiones; Preste atención al borde afilado de algunas partes.
- 3 Los niños y las mascotas no pueden ingresar al sitio de construcción.
- 4 Nunca concentre su peso total en el techo del edificio. Cuando utilice una escalera de mano, asegúrese de que sea segura.

Cuidado y Mantenimiento

- 1 Mantenga limpio el cobertizo con un paño suave, use agua si es necesario.
- 2 Mantenga los rieles de las puertas libres de suciedad y otras cosas que eviten que se deslicen fácilmente.
- 3 Limpie la nieve con las herramientas necesarias para asegurarse de que sea seguro ingresar; Las fuertes nevadas pueden provocar un colapso, por favor asegúrese de seguridad antes de entrar.
- 4 El cobertizo no está hecho para vivir sino para almacenar cosas.

PREPARAÇÃO DA MONTAGEM

favor, verifique os regulamentos locais de construção no que diz respeito a pavimentos, localização e outros requisitos antes de iniciar a construção. Leia e compreenda este manual do proprietário com informações importantes e dicas úteis para uma montagem mais fácil e mais prazerosa.

Instruções de montagem:

Rever todas as instruções e a informação apropriada antes de começar, certificar-se de seguir cuidadosamente a sequência de passos para obter resultados bem sucedidos.

Base de pavimento:

O local deve ser preparado de modo a que a base do galpão esteja nivelada em toda a volta e é necessário verificar com um nível de espírito.

A base pode ser construída com madeira tratada ou betão, a fim de impedir que a humidade entre no barracão, O barracão não foi concebido para ser construído directamente sobre a relva, e o solo também ficará lamacento durante os dias de chuva.

Se for feita uma almofada de betão, é importante que este desnível se incline para as margens para evitar a entrada de água, deve ser dado tempo para que qualquer betão ou cimento seque antes de construir o barracão no topo.

As bases também podem ser construídas a partir de tijolos, blocos, ou montadas sobre uma almofada de betão.

Os tijolos ou blocos devem ser cimentados em sapatas de betão firmes e niveladas e a armação da estufa deve ser perfurada e aparafusada à base.

Lista de peças:

Antes de começar, separe e identifique todas as peças e equipamentos para ter a certeza de que tem todas as peças necessárias para o seu abrigo (consulte a página Lista de Peças).

Não tente montar o abrigo se faltarem peças porque qualquer abrigo deixado parcialmente montado pode ser seriamente danificado por ventos fracos.

A segurança deve ser colocada na posição nº 1:

- 1 Seleccione um dia seco e calmo para a sua montagem. Trabalhos de equipa (duas ou mais pessoas) são necessários durante a montagem;
- 2 Usar luvas de segurança, protecção dos olhos e mangas compridas durante a montagem para evitar ferimentos; Prestar atenção à aresta afiada de algumas peças;
- 3 Não é permitida a entrada de crianças e animais de estimação no abrigo durante a construção;
- 4 Nunca concentre o seu peso total no telhado do edifício. Ao utilizar uma escada de mão, certifique-se de que é segura;

Cuidados e Manutenção:

- 1 Mantenha o abrigo limpo com um pano macio, use água se necessário;
- 2 Mantenha os caminhos das portas livres de sujidade e outras coisas que os impeçam de deslizar facilmente.
- 3 Limpar a neve com as ferramentas necessárias para garantir que é seguro entrar; A neve pesada pode causar desmoronamento, por favor, garantir a segurança antes de entrar.
- 4 O abrigo não é feito para viver, mas para armazenar coisas.

VORBEREITUNG FÜR DIE MONTAGE

Vor Beginn der Bauarbeiten überprüfen Sie bitte die örtlichen Bauvorschriften in Bezug auf Fußböden, Standort und andere Anforderungen. Lesen und verstehen Sie diese Bedienungsanleitung mit wichtigen Informationen und hilfreichen Tipps für eine einfachere und angenehmere Montage.

Montageanweisung:

Überprüfen Sie alle Anweisungen und die entsprechenden Informationen, bevor Sie beginnen. Stellen Sie bitte sicher, dass Sie die Schrittsequenz sorgfältig befolgen, um erfolgreiche Ergebnisse zu erzielen.

Bodenbelag:

Der Standort muss so vorbereitet werden, dass der Boden des Schuppens rundum eben ist, und eine Überprüfung mit einer Wasserwaage ist erforderlich.

Der Sockel kann aus behandeltem Holz oder Beton hergestellt werden, um das Eindringen von Feuchtigkeit in den Schuppen zu verhindern. Der Schuppen ist nicht dafür vorgesehen, direkt auf Rasenflächen gebaut zu werden. Auch der Boden wird an Regentagen matschig.

Wenn eine Betonplatte hergestellt wird, ist es wichtig, dass diese zu den Rändern hin geneigt ist, um das Eindringen von Wasser zu verhindern.

Vor dem Bau des Schuppens muss Zeit zum Trocknen von Beton oder Zement eingeplant werden.

Die Fundamente können auch aus Ziegelsteinen oder Blöcken gebaut oder auf eine Betonplatte montiert werden.

Die Ziegel oder Blöcke sollten auf feste und ebene Betonfundamente zementiert und der Gewächshausrahmen gebohrt und mit dem Sockel verschraubt werden.

Teile und Teileliste:

Bevor Sie beginnen, trennen und identifizieren Sie alle Teile und Hardware, um sicherzustellen, dass Sie alle erforderlichen Teile für Ihr Gebäude haben (siehe Seite Teileliste).

Versuchen Sie nicht, das Gebäude zusammenzubauen, wenn Teile fehlen, da ein teilweise zusammengebautes Gebäude durch leichten Wind ernsthaft beschädigt werden kann.

Achten Sie erst auf die Sicherheit :

1 Wählen Sie einen trockenen und ruhigen Tag für Ihre Montage aus. Teamarbeiten (Zwei oder mehr Personen) sind während der Montage erforderlich;

2 Tragen Sie die Schutzhandschuhen, Augenschutz und langen Ärmeln bei der Montage zur Vermeidung von Verletzungen; Achten Sie auf die scharfe Kante für einige Teile;

3 Die Kinder und Haustiere dürfen nicht auf die Baustelle betreten;

4 Konzentrieren Sie niemals Ihr Gesamtgewicht auf das Dach des Gebäudes. Bei Verwendung einer Trittleiter sollen Sie die Sicherheit gewährleisten.

Pflege und Wartung:

1 Halten Sie den Schuppen mit einem weichen Tuch sauber, verwenden Sie das Wasser wenn nötig;

2 Halten Sie die Türschiene von Schmutz und anderen Gegenständen fern, damit sie nicht leicht verrutschen können.

3 Reinigen Sie den Schnee mit den notwendigen Werkzeugen, um sicherzugehen, dass Sie sicher betreten können; Starker Schneefall kann zum Einsturz führen, bitte gewährleisten Sie die Sicherheit vor dem Betreten .

4 Der Schuppen ist nicht zum Wohnen gemacht, sondern zum Aufbewahren von Sachen.

MONTAGGIO

Prima di iniziare, si prega di verificare i regolamenti edilizi locali relativi alle fondamenta, alla posizione e ad altri requisiti. Si prega di studiare e comprendere questo manuale di informazioni importanti e suggerimenti utili per un assemblaggio più semplice.

Istruzioni di assemblaggio:

Si prega di visionare tutte le istruzioni e le informazioni prima di iniziare, accertandosi di seguire attentamente la sequenza di passaggi.

Fondazione del pavimento:

L'area deve essere preparata in modo che la base del capannone sia livellata tutt'intorno ed è necessario verificare con una livella a bolla d'aria.

Le fondamenta possono essere costruite in legno trattato o cemento, per impedire che l'umidità penetri nel capannone. **Il capannone non è progettato per essere costruito direttamente sul prato.** Il terreno diventerà fangoso durante i giorni di pioggia.

Se viene posizionato su un blocco di cemento, è importante che esso sia inclinato ai bordi per evitare l'ingresso di acqua.

È necessario attendere che il calcestruzzo o il cemento si asciughino prima di costruirvi sopra il capannone.

Le fondamenta possono anche essere costruite da mattoni, blocchi o direttamente da un blocco di cemento.

I mattoni devono essere cementati su basi di cemento solide e livellate in piano, e il telaio del capannone va forato e avvitato alla base.

Parti e lista delle parti:

Prima di iniziare, separare e identificare tutte le parti e l'hardware per essere sicuri di disporre di tutte le parti necessarie per la costruzione (fare riferimento alla pagina della Lista delle Parti).

Non tentare di montare la costruzione se mancano parti perché qualsiasi costruzione lasciata parzialmente assemblata può essere seriamente danneggiata da venti leggeri.

La sicurezza deve venire prima di tutto:

- 1 Scegli un giorno asciutto e calmo per il tuo assemblaggio. Il lavoro di gruppo (due o più persone) è richiesto durante l'assemblaggio;
- 2 Indossare guanti di sicurezza, occhiali protettivi e maniche lunghe durante l'assemblaggio per evitare lesioni. Prestare attenzione al bordo tagliente di alcune parti;
- 3 Ai bambini e agli animali domestici non è consentito entrare nel cantiere;
- 4 Non concentrare mai il peso totale sul tetto dell'edificio. Quando si utilizza una scala a pioli, assicurarsi che sia sicura;

Manutenzione:

- 1 Tenere il capanno pulito con un panno morbido, usare acqua se necessario;
- 2 Tenere i binari della porta liberi da sporcizia e altre cose che impediscano loro di scivolare facilmente.
- 3 Pulisci la neve con gli strumenti necessari per assicurarti che sia sicuro entrare; La neve pesante può causare il collasso, controlla che sia sicuro prima di entrare.
- 4 Il capanno non è ideato come zona abitativa, ma solo come magazzino.

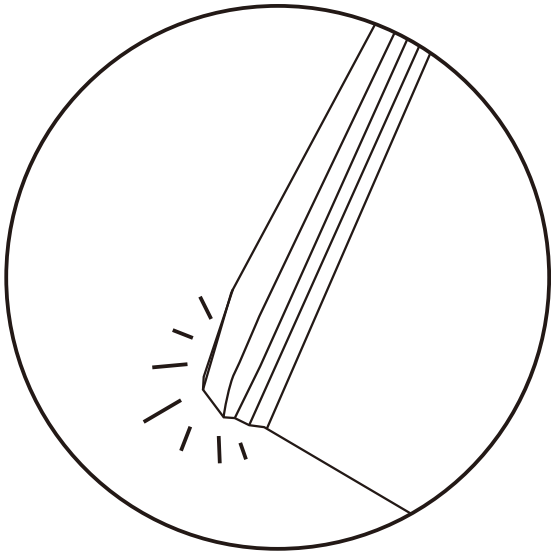

EN_NOTICE: If there is slight bending on the corners

FR_AVIS : En cas de légère courbure des angles

ES_NOTA: Si hay una ligera flexión en las esquinas

PT_AVISO: Se houver uma ligeira dobragem nas esquinas

DE_HINWEIS: Wenn die Ecken leicht gebogen sind

IT_AVVISO: Qualora ci fosse una leggera flessione sugli angoli

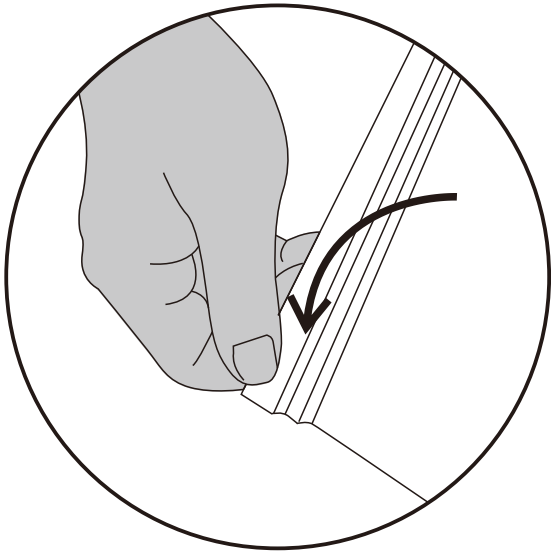

EN_1. Pls wear gloves and stretch the corners slightly until they are flat

FR_1. Veuillez porter des gants et exercer une légère torsion sur les bords jusqu'à ce qu'ils soient plats

ES_1. Por favor, use guantes y estire las esquinas ligeramente hasta que queden planas

PT_1. Utilize uma luva e estique ligeiramente os cantos até que estejam normais

DE_1. Bitte tragen Sie Handschuhe und dehnen Sie die Ecken leicht, bis sie flach sind

IT_1. Si prega di indossare dei guanti e di allungare leggermente gli angoli fino a quando non si sono appiattiti

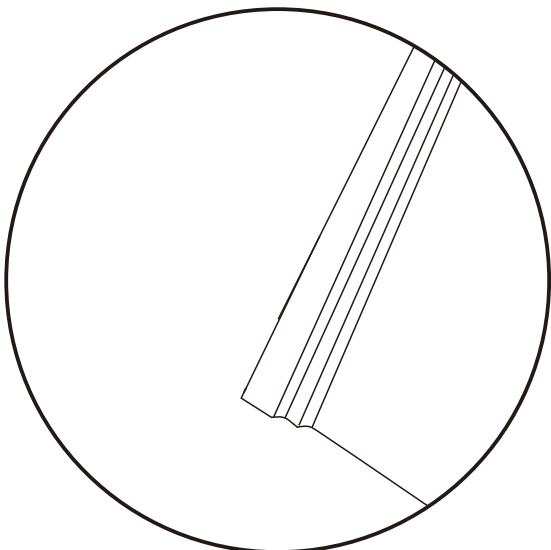

EN_2. Then the sheets will be normal and there is no effect on the assembling

FR_2. Les feuilles deviennent alors normales ; sans incidence sur l'assemblage.

ES_2. Entonces las hojas serán normales y no hay ninguna influencia sobre el ensamblaje

PT_2. Em seguida, os painéis estarão normais e não há efeito sobre a montagem

DE_2. Dann sind die Platten normal und es gibt keine Auswirkungen auf den Zusammenbau

IT_2. Quindi le lastre torneranno normali e non vi sarà alcun effetto sull'assemblaggio

EN

1. Pay attention to the sharp edge of some parts.
2. Wearing safety gloves, eye protection and long sleeves during the assembly to prevent injury.
3. Children and pets are not allowed entering into the construction site.

**FR**

1. Faites attention au bord tranchant de certaines parties.
2. Porter des gants de protection, des lunettes de protection et des manches longues pendant le montage pour éviter les blessures.
3. Les enfants et les animaux domestiques ne sont pas admis sur le chantier de construction.

ES

1. Preste atención al borde afilado de algunas partes.
2. Use guantes de seguridad, protección ocular y mangas largas durante el montaje para evitar lesiones.
3. Los niños y las mascotas no pueden ingresar al sitio de construcción.

PT

1. Prestar atenção à aresta afiada de algumas peças.
2. Usar luvas de segurança, protecção dos olhos e mangas compridas durante a montagem para evitar ferimentos.
3. Não é permitida a entrada de crianças e animais de estimação no abrigo durante a construção.

DE

1. Achten Sie auf die scharfe Kante für einige Teile.
2. Tragen Sie die Schutzhandschuhen, Augenschutz und langen Ärmeln bei der Montage zur Vermeidung von Verletzungen.
3. Die Kinder und Haustiere dürfen nicht auf die Baustelle betreten.

IT

1. Prestare attenzione al bordo tagliente di alcune parti.
2. Indossare guanti di sicurezza, occhiali protettivi e maniche lunghe durante l'assemblaggio per evitare lesioni.
3. Ai bambini e agli animali domestici non è consentito entrare nel cantiere.

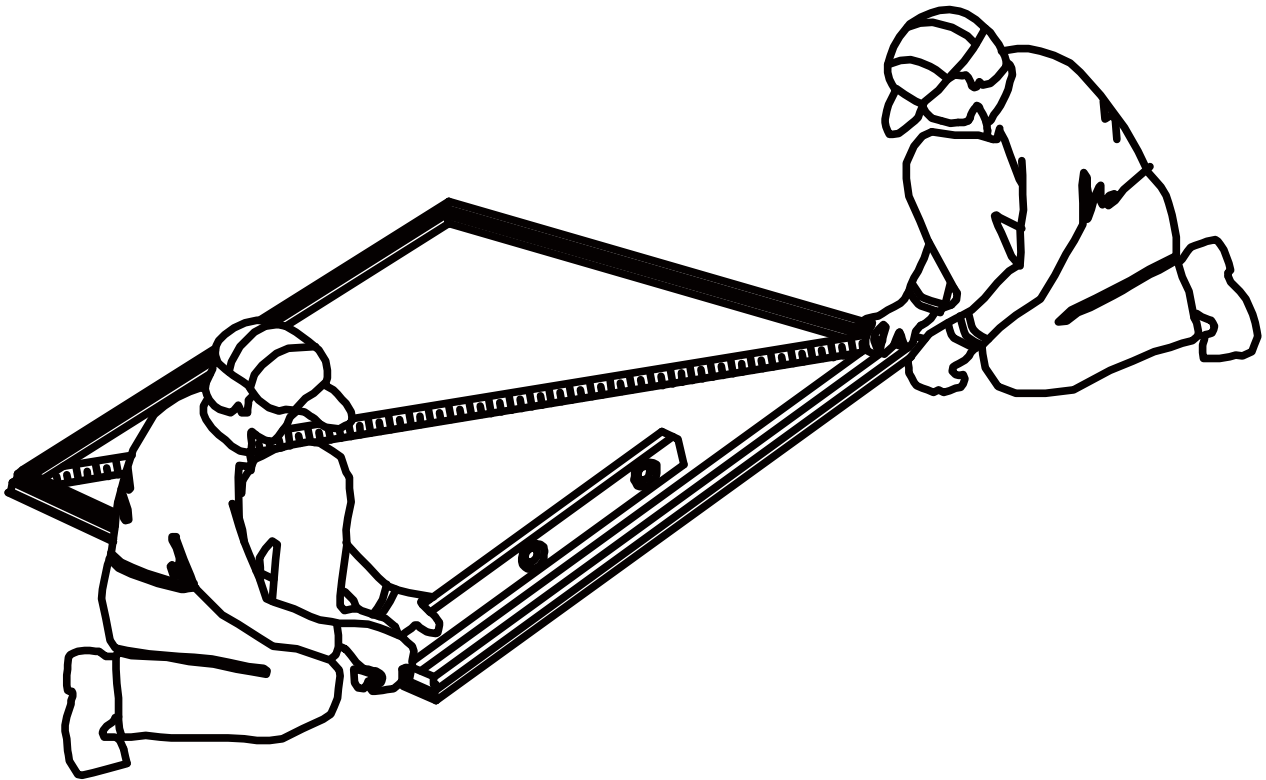

EN:

1. When diagonal measurements are equal, the frame is square.
2. The Floor Frame must be BOTH square AND level or the holes will not line up properly.

FR:

1. lorsque les mesures diagonales sont égales, le cadre est carré.
2. le cadre de plancher doit être à la fois carré ET de niveau ou les trous ne s'aligneront pas correctement.

ES:

1. Cuando las medidas diagonales son iguales, el marco es cuadrado.
2. El marco del piso debe estar TANTO a escuadra como nivelado o los orificios no se alinearán correctamente.

PT:

1. quando as medidas diagonais são iguais, a moldura é quadrada.
2. a moldura do chão deve ser AMBOSA quadrada E nivelada ou os buracos não se alinharão correctamente.

DE:

1. Wenn die diagonalen Maße gleich sind, ist der Rahmen quadratisch.
2. Der Bodenrahmen muss sowohl quadratisch als auch eben sein, da sonst die Löcher nicht richtig ausgerichtet sind.

IT:

1. Quando le misure diagonali sono uguali, la cornice è quadrata.
2. Il telaio del pavimento deve essere SIA quadrato CHE a livello o i fori non si allineeranno correttamente.

BOX-1/3













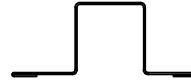

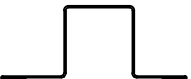

BP2	2
CP1	2
BPD1-1	1
BPD1-2	1
BPD2-1	1
BPD2-2	1
ZT1	2
ZT2	2
ZD1	2
ZD2-1	1
ZD2-2	1
ZD3-1	1
ZD3-2	1
ZD4	1
hardwre kit	



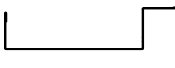

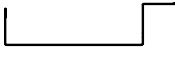

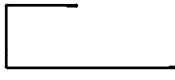

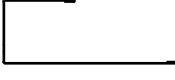

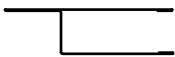
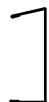

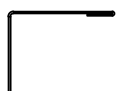
BOX-2/3

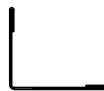



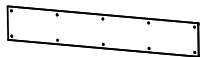
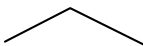

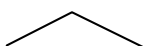
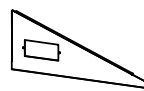







BP1	28
-----	----







BOX-3/3

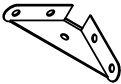

ZB1	2
ZB2	2
ZB3	1
ZB4	1
ZB5	1
ZB6	1
ZJ1-1	1
ZJ1-2	1
ZJ2-1	1
ZJ2-2	1
ZJ3	1
BC1	2
BC2	2
BC3	2
ZA1	4
ZA2	2
ZA3	4
ZR1	2
ZR2	1
D1	2
D2	2
D3	1
D4	1
D5	1
D6	1
D7	1
D8	3
D9	2
D10	1
D11	1
D12	1
D13	1
ED1	2
ED2	2

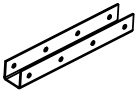
Item no.	Reference Image	Qty.	Item no.	Reference Image	Qty.
BP1		28	ZB2		2
BP2		2	ZB3		1
CP1		2	ZB4		1
BP11		10	ZB5		1
BPD1-1		1	ZB6		1
BPD1-2		1	ZJ1-1		1
BPD2-1		1	ZJ1-2		1
BPD2-2		1	ZJ2-1		1
ZB1		2	ZJ2-2		1

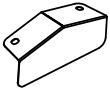
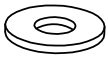
Item no.	Reference Image	Qty.	Item no.	Reference Image	Qty.
ZJ3		1	BC1		2
ZD1		2	BC2		2
ZD2-1		1	BC3		2
ZD2-2		1	ZA1		4
ZD3-1		1	ZA2		2
ZD3-2		1	ZA3		4
ZD4		1	ZR1		2
ZT1		2	ZR2		1
ZT2		2	D1		2

Item no.	Reference Image	Qty.	Item no.	Reference Image	Qty.
D2		2	D11		1
D3		1	D12		1
D4		1	D13		1
D5		1	ED1		2
D6		1	ED2		2
D7		4			
D8		3			
D9		2			
D10		1			

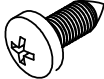
Item no.	Reference Image	Qty.
MV1		4
K18		9
K27		2
K21		8
K49		2
L4		1
LG1		2
M3		92
M4		42

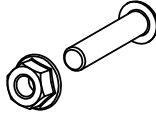
Item no.	Reference Image	Qty.
M12		4
S14		485
S15		6
S19		28
S21		16
S32		4

ASSEMBLY BY KEY NO.

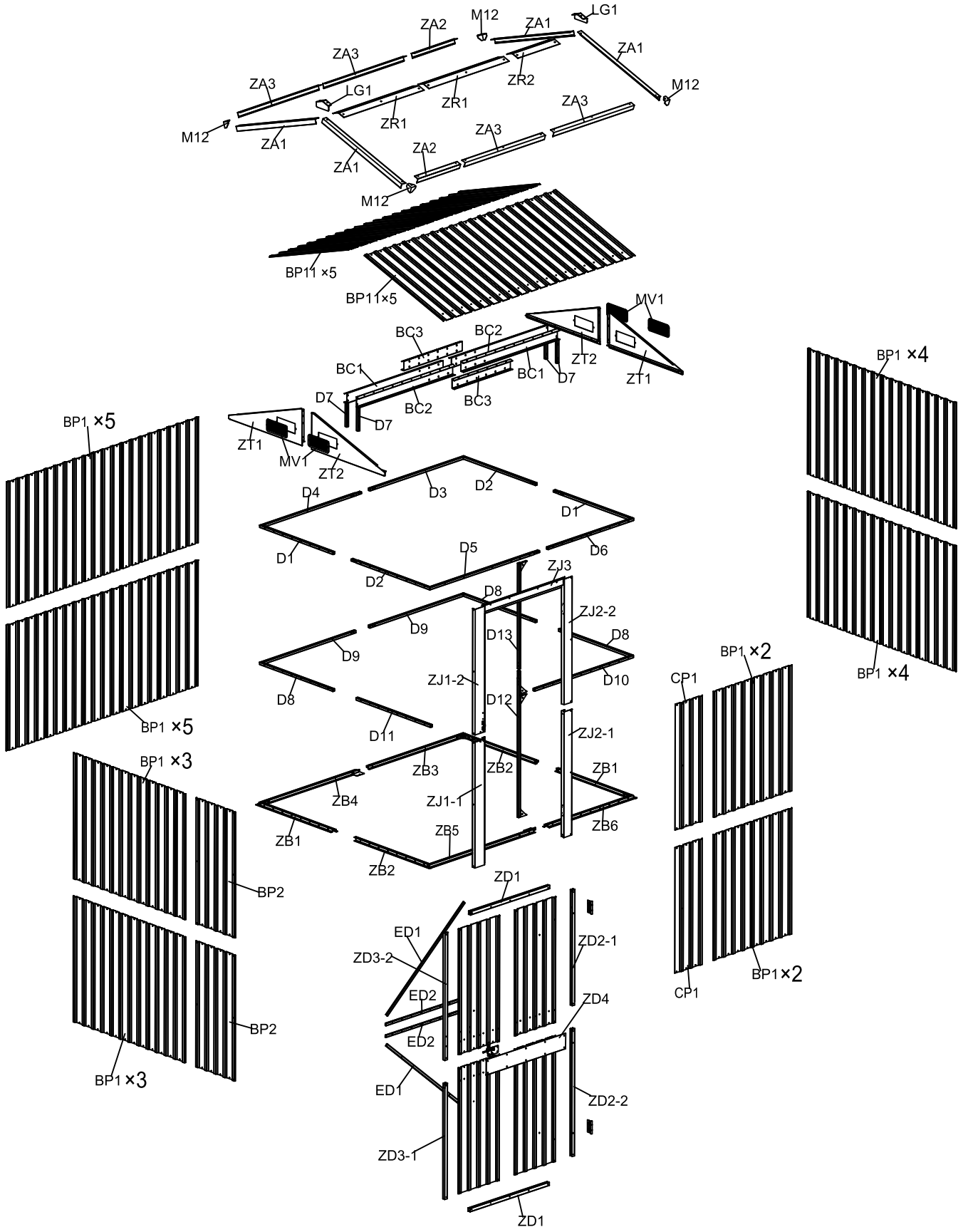

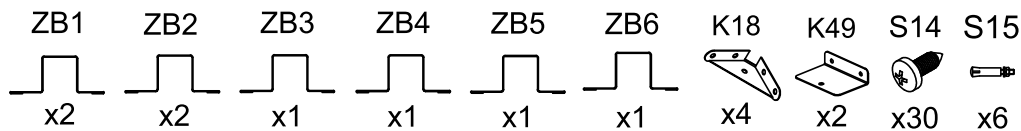

EN_ 1. Refer to the foundation structure Figure , draw lines on the ground for positioning.

all dimension lines are drawn from the center of the pipe to the center.

2.Fixed on the ground with (S15) expansion bolts.

FR_ 1. Reportez-vous à la figure représentant la structure de fondation, tracez des lignes au sol pour le positionnement.

Toutes les lignes dimensionnelles sont tracées du centre du tuyau vers le centre.

2. Fixez au sol à l'aide de boulons à expansion (S15).

ES_ 1. Consulte la estructura de los cimientos en la figura y dibuje líneas en el suelo para el posicionamiento.

Todas las líneas de dimensión se dibujan desde el centro de la tubería hasta el centro.

2. Fíjelo al suelo con pernos de expansión (S15).

PT_ 1. Consulte a estrutura da fundação na Figura e trace linhas no solo para posicionamento.

Todas as linhas de dimensão são traçadas do centro do tubo até o centro.

2. Fixe no solo com parafusos de expansão (S15).

DE_ 1. Beziehen Sie sich auf die Fundamentstruktur Abbildung und zeichnen Sie Linien auf den Boden, um die Position zu bestimmen.

Alle Maßlinien werden von der Mitte des Rohrs zur Mitte gezogen.

2. Mit (S15) Dehnschrauben am Boden befestigen.

IT_ 1. Fare riferimento alla struttura di fondazione Figura , tracciare delle linee sul terreno per il posizionamento.

Tutte le linee di dimensione sono tracciate dal centro del tubo al centro.

2. Fissare al terreno con bulloni di espansione (S15).



EN_ Check the dimensions to ensure that the installation direction and position of each component are correct.

FR_ Vérifiez les dimensions pour vous assurer que le sens d'installation et la position de chaque composant sont corrects.

ES_ Compruebe las dimensiones para asegurarse de que la dirección y la posición de instalación de cada componente sean correctas.

PT_ Verifique as dimensões para garantir que a direção e a posição de instalação de cada componente estejam corretas.



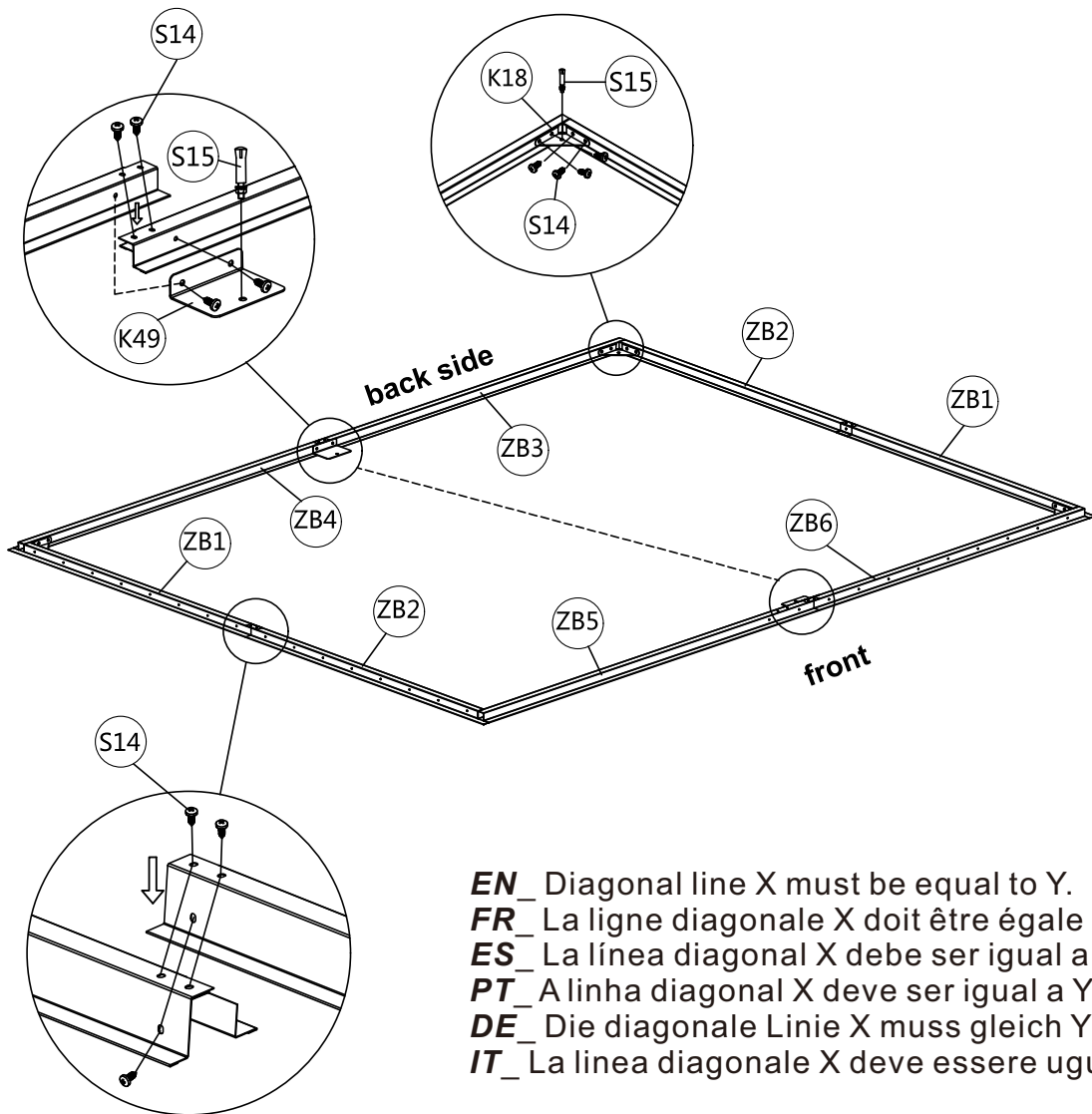

DE_ Überprüfen Sie die Abmessungen, um sicherzustellen, dass die Einbaurichtung und Position jeder Komponente korrekt sind.

IT_ Controllare le dimensioni per assicurarsi che la direzione di installazione e la posizione di ciascun componente siano corrette.

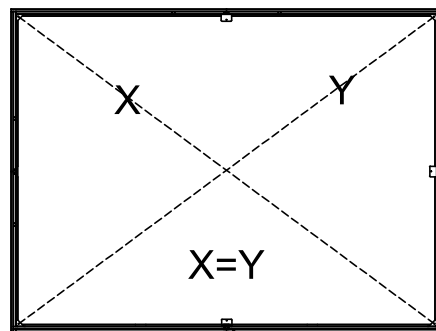

- EN_** Diagonal line X must be equal to Y.
- FR_** La ligne diagonale X doit être égale à Y.
- ES_** La línea diagonal X debe ser igual a Y.
- PT_** A linha diagonal X deve ser igual a Y.
- DE_** Die diagonale Linie X muss gleich Y sein.
- IT_** La linea diagonale X deve essere uguale a Y.



BP1	D8	D9	S14
			
x2	x1	x1	x9

EN_ Use a temporary screw at the top tile to secure the frame. Important: Remove this screw during a later installation step.

FR_ Utilisez une vis temporaire au niveau de la tuile supérieure pour fixer le cadre. Important : retirez cette vis lors d'une étape ultérieure de l'installation.

ES_ Utilice un tornillo temporal en la baldosa superior para fijar el marco. Importante: Retire este tornillo durante un paso posterior de la instalación.

PT_ Use um parafuso temporário na telha superior para fixar a moldura. Importante: remova este parafuso durante uma etapa posterior da instalação.

DE_ Befestigen Sie den Rahmen mit einer provisorischen Schraube an der obersten Fliese. Wichtig: Entfernen Sie diese Schraube bei einem späteren Installationsschritt.

IT_ Utilizzare una vite provvisoria nella piastrella superiore per fissare il telaio. Importante: rimuovere questa vite durante una fase successiva dell'installazione.

EN_ Install with the notch facing the same direction.

FR_ Installez-le avec l'encoche orientée dans le même sens.

ES_ Instálolo con la muesca orientada en la misma dirección.

PT_ Instale com o entalhe voltado para a mesma direção.

DE_ Installieren Sie das Teil so, dass die Kerbe in die gleiche Richtung zeigt.

IT_ Installare con l'incavo rivolto nella stessa direzione.

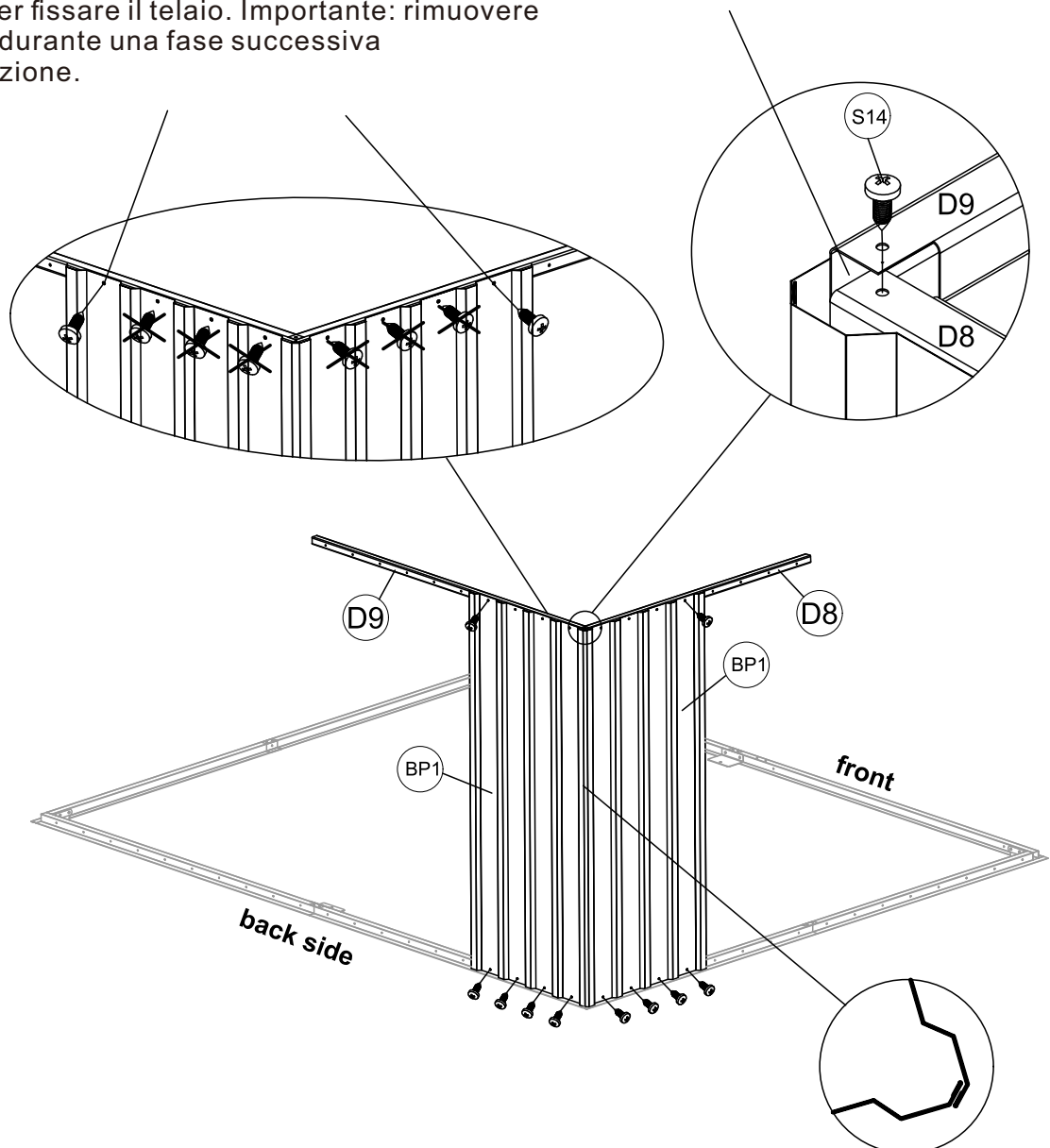

BP1



x1

BP2



x1

D9



x1

D11



x1

K21



x2

S14



x16

Step 1

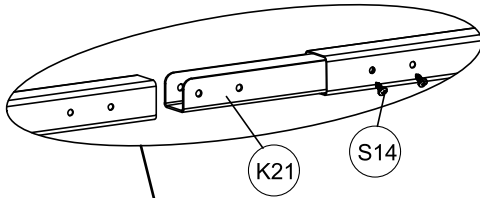

Step 2

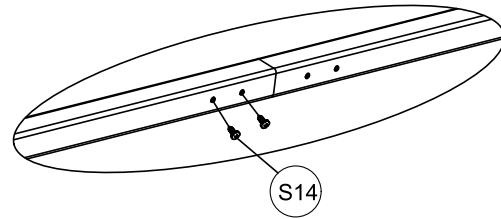

EN_ Use a temporary screw at the top tile to secure the frame. Important: Remove this screw during a later installation step.

FR_ Utilisez une vis temporaire au niveau de la tuile supérieure pour fixer le cadre. Important : retirez cette vis lors d'une étape ultérieure de l'installation.

ES_ Utilice un tornillo temporal en la baldosa superior para fijar el marco. Importante: Retire este tornillo durante un paso posterior de la instalación.

PT_ Use um parafuso temporário na telha superior para fixar a moldura. Importante: remova este parafuso durante uma etapa posterior da instalação.

DE_ Befestigen Sie den Rahmen mit einer provisorischen Schraube an der obersten Fliese. Wichtig: Entfernen Sie diese Schraube bei einem späteren Installationsschritt.

IT_ Utilizzare una vite provvisoria nella piastrella superiore per fissare il telaio. Importante: rimuovere questa vite durante una fase successiva dell'installazione.

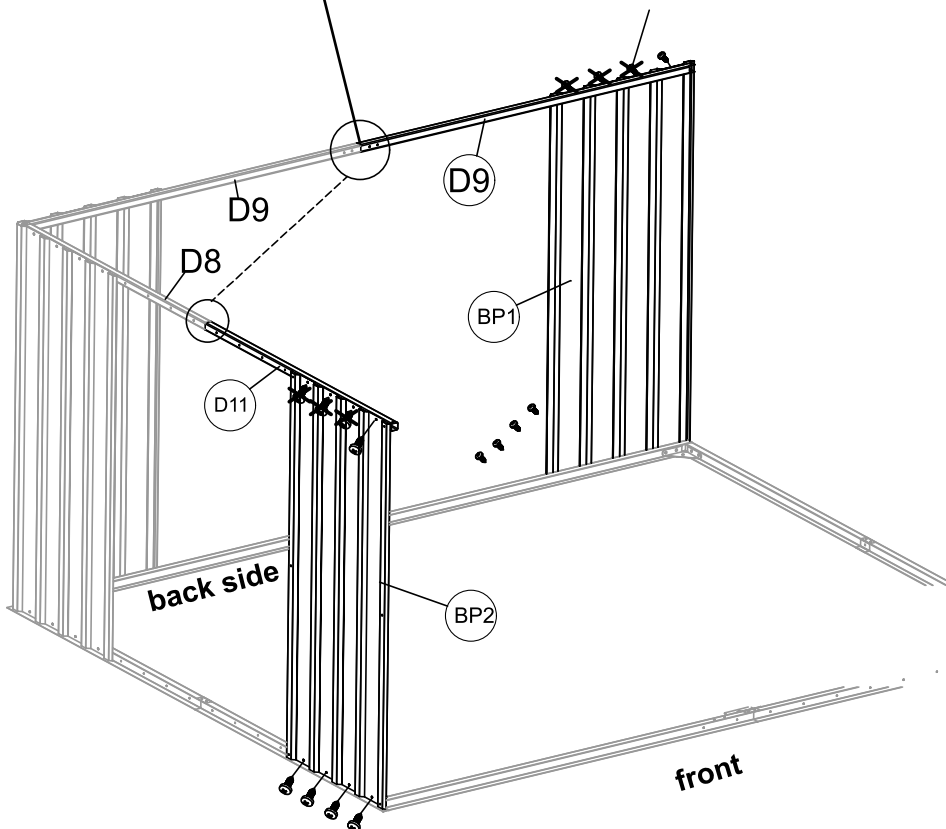

BP1



x1

BP2



x1

D9



x1

D11



x1

K21



x2

S14



x16

EN_ During installation, please note the orientation of the notch.

FR_ Lors de l'installation, veuillez tenir compte de l'orientation de l'encoche.

ES_ Durante la instalación, tenga en cuenta la orientación de la muesca.

PT_ Durante a instalação, observe a orientação do entalhe.

DE_ Beachten Sie bei der Installation bitte die Ausrichtung der Kerbe.

IT_ Durante l'installazione, prestare attenzione all'orientamento dell'incavo.

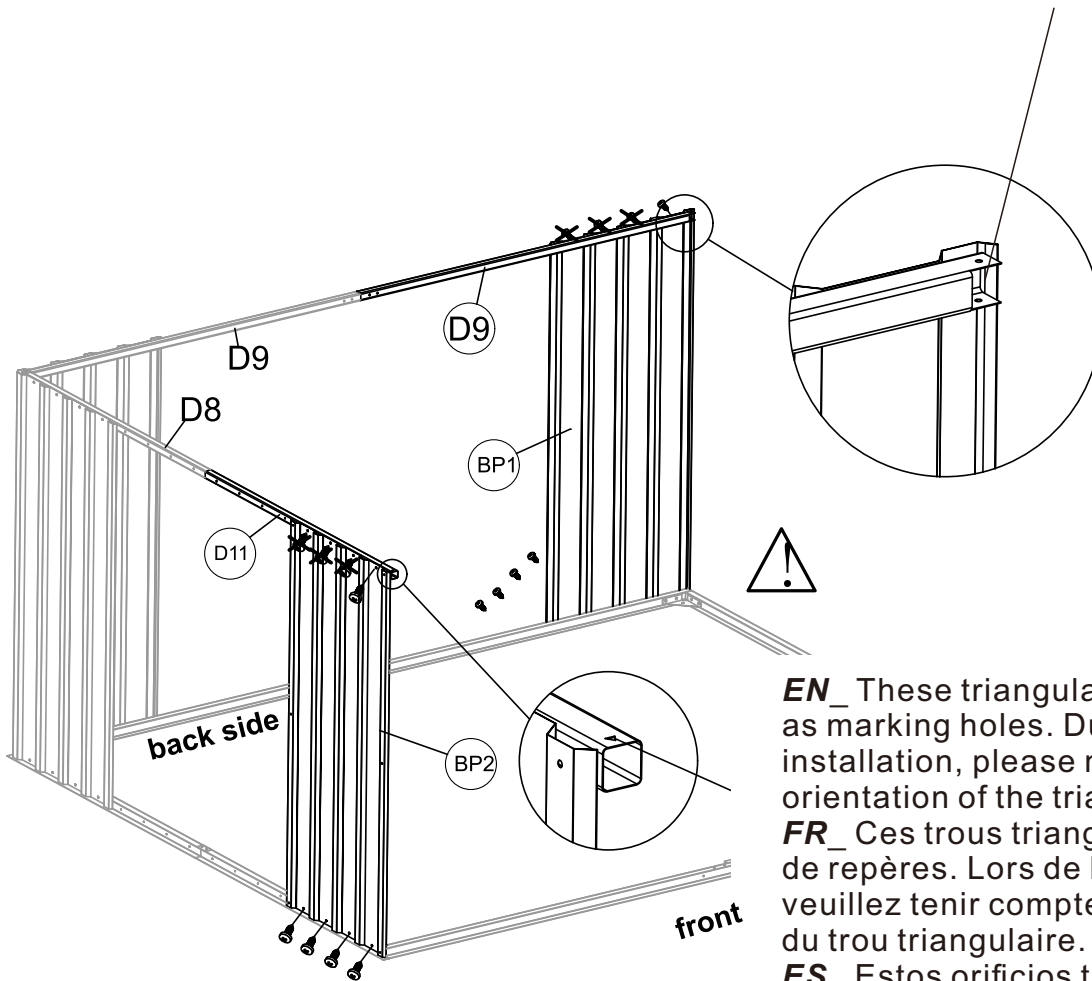

EN_ These triangular holes are used as marking holes. During installation, please note the orientation of the triangular hole.





FR_ Ces trous triangulaires servent de repères. Lors de l'installation, veuillez tenir compte de l'orientation du trou triangulaire.

ES_ Estos orificios triangulares se utilizan como orificios de marcado. Durante la instalación, tenga en cuenta la orientación del orificio triangular.

PT_ Estes orifícios triangulares são utilizados como orifícios de marcação. Durante a instalação, tenha em atenção a orientação do orifício triangular.

DE_ Diese dreieckigen Löcher dienen als Markierungslöcher. Beachten Sie bei der Installation bitte die Ausrichtung des dreieckigen Lochs.

IT_ Questi fori triangolari servono come fori di riferimento. Durante l'installazione, prestare attenzione all'orientamento del foro triangolare.

BP1	D8	K21	S14
			
x2	x2	x1	x13

Step 1

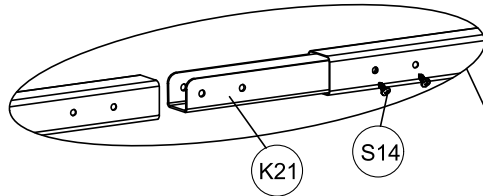

Step 2

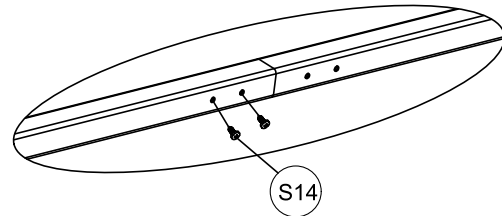

EN_ Use a temporary screw at the top tile to secure the frame. Important: Remove this screw during a later installation step.

FR_ Utilisez une vis temporaire au niveau de la tuile supérieure pour fixer le cadre. Important : retirez cette vis lors d'une étape ultérieure de l'installation.



ES_ Utilice un tornillo temporal en la baldosa superior para fijar el marco. Importante: Retire este tornillo durante un paso posterior de la instalación.

PT_ Use um parafuso temporário na telha superior para fixar a moldura. Importante: remova este parafuso durante uma etapa posterior da instalação.

DE_ Befestigen Sie den Rahmen mit einer provisorischen Schraube an der obersten Fliese. Wichtig: Entfernen Sie diese Schraube bei einem späteren Installationsschritt.

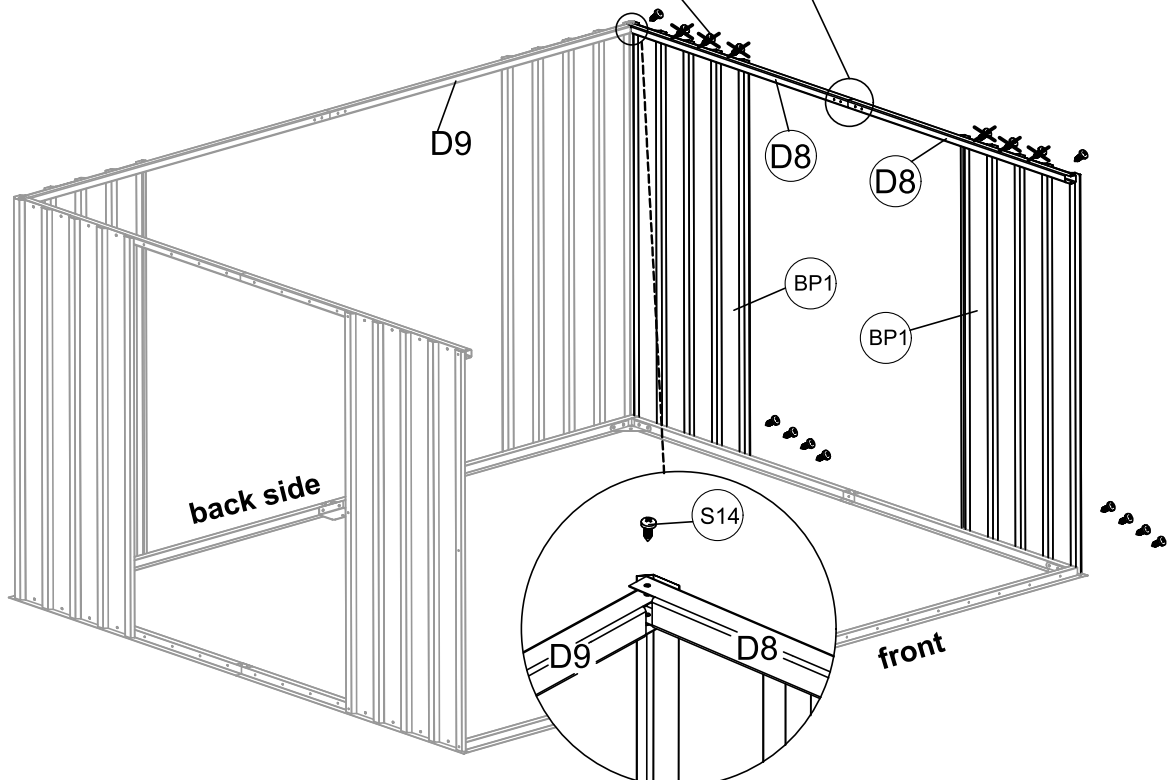
IT_ Utilizzare una vite provvisoria nella piastrella superiore per fissare il telaio. Importante: rimuovere questa vite durante una fase successiva dell'installazione.



BP1	D10	S14
		
x1	x1	x5

EN_ Use a temporary screw at the top tile to secure the frame. Important: Remove this screw during a later installation step.

FR_ Utilisez une vis temporaire au niveau de la tuile supérieure pour fixer le cadre. Important : retirez cette vis lors d'une étape ultérieure de l'installation.

ES_ Utilice un tornillo temporal en la baldosa superior para fijar el marco. Importante: Retire este tornillo durante un paso posterior de la instalación.

PT_ Use um parafuso temporário na telha superior para fixar a moldura. Importante: remova este parafuso durante uma etapa posterior da instalação.

DE_ Befestigen Sie den Rahmen mit einer provisorischen Schraube an der obersten Fliese. Wichtig: Entfernen Sie diese Schraube bei einem späteren Installationsschritt.

IT_ Utilizzare una vite provvisoria nella piastrella superiore per fissare il telaio. Importante: rimuovere questa vite durante una fase successiva dell'installazione.

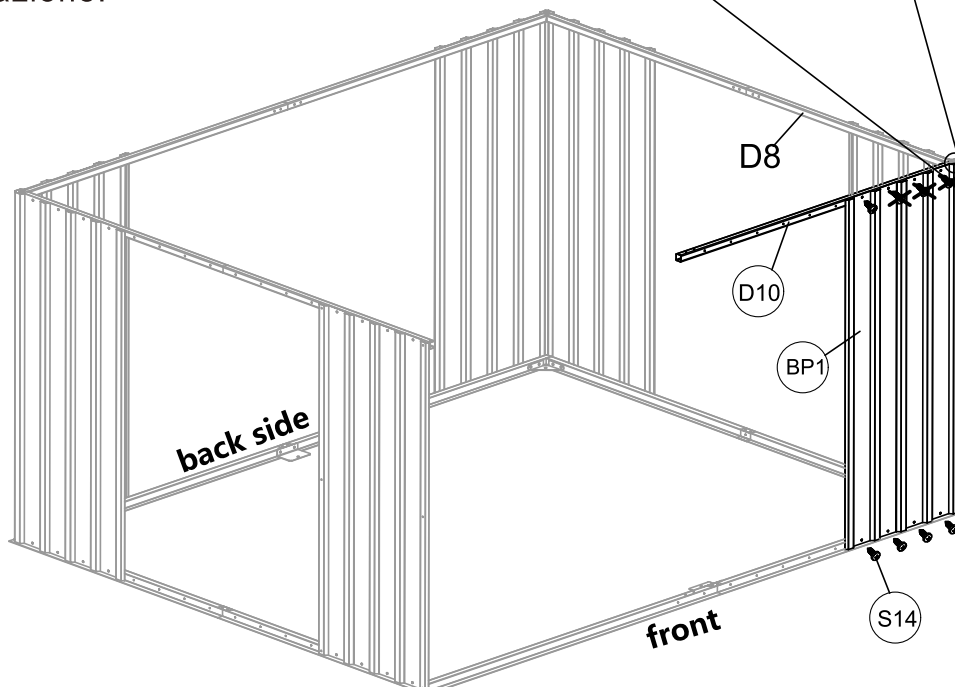
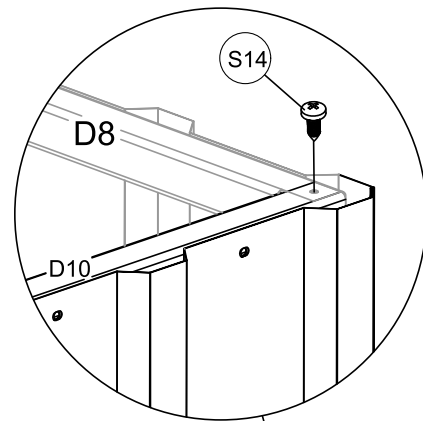

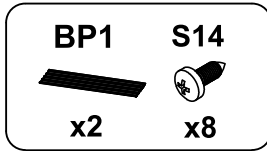

EN_ This installation method establishes the standard procedure for all following steps. It will not be detailed again.

FR_ Cette méthode d'installation établit la procédure standard pour toutes les étapes suivantes. Elle ne sera pas détaillée à nouveau.

ES_ Este método de instalación establece el procedimiento estándar para todos los pasos siguientes. No se volverá a detallar.

PT_ Este método de instalação estabelece o procedimento padrão para todas as etapas seguintes. Não será detalhado novamente.

DE_ Diese Installationsmethode legt das Standardverfahren für alle folgenden Schritte fest. Es wird nicht erneut detailliert beschrieben.

IT_ Questo metodo di installazione stabilisce la procedura standard per tutti i passaggi successivi. Non verrà descritto nuovamente in dettaglio.

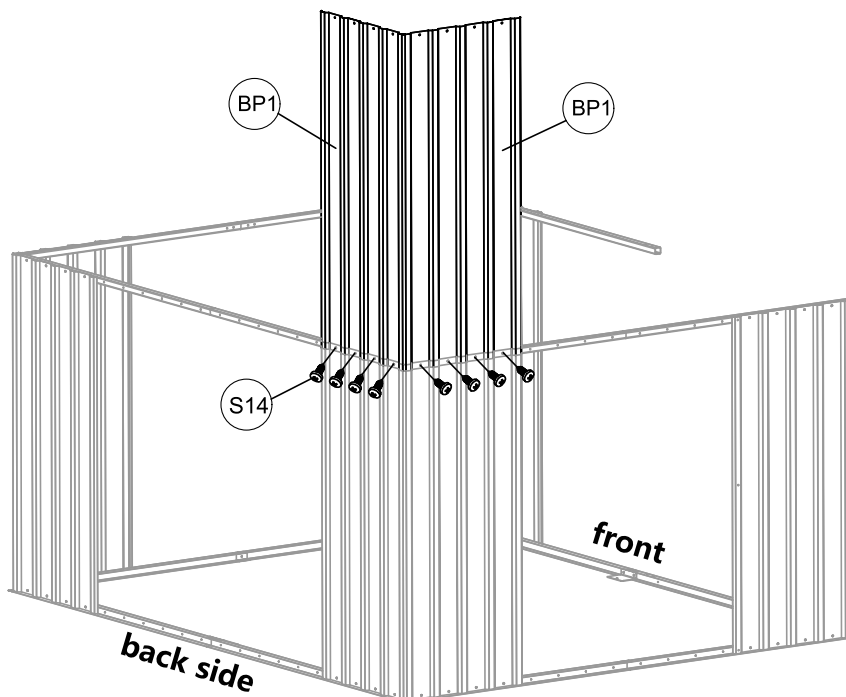

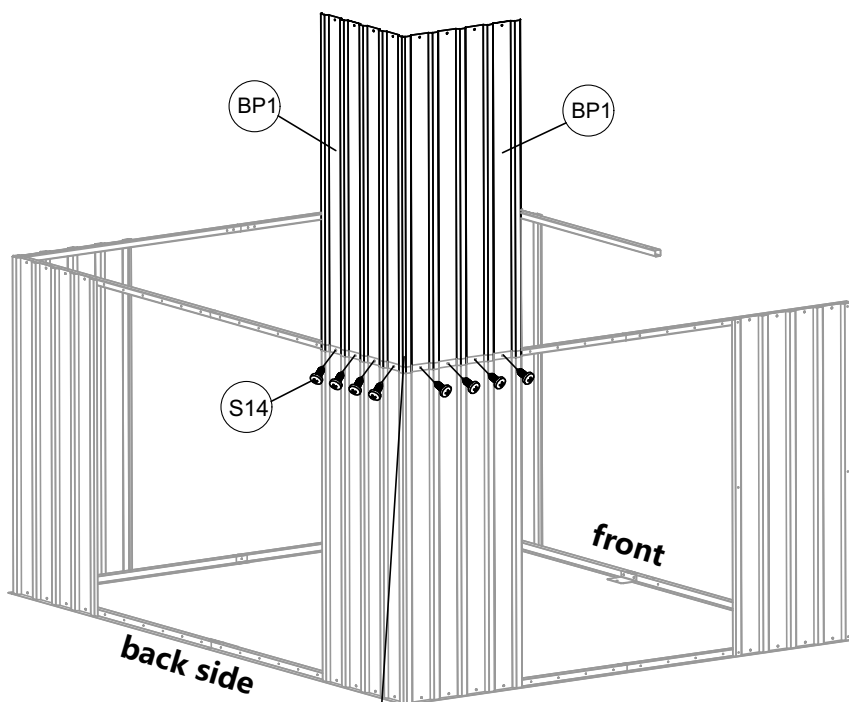

Step 1

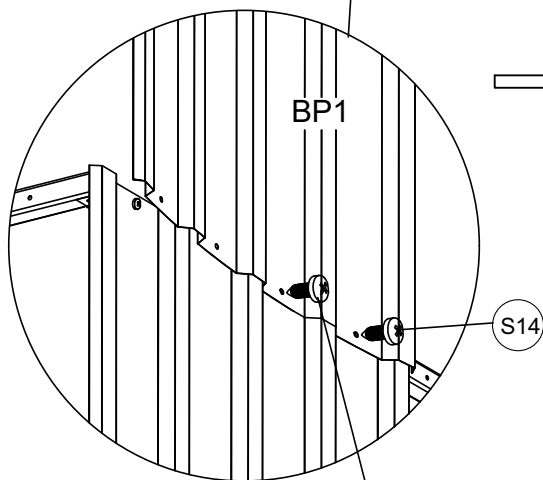

Step 2

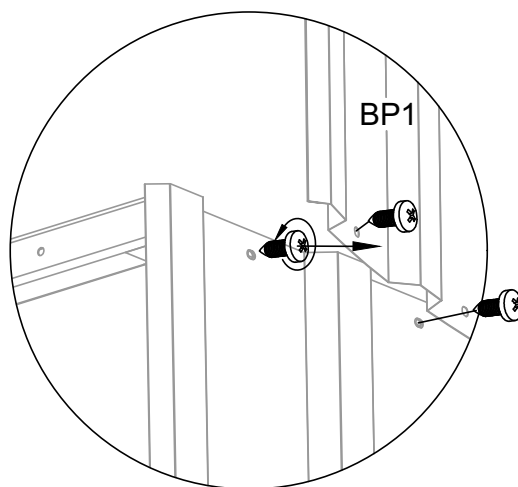

EN_ Install two screws on the side opposite the previously temporary fixation point.

FR_ Installez deux vis sur le côté opposé au point de fixation temporaire précédent.

ES_ Instale dos tornillos en el lado opuesto al punto de fijación temporal anterior.

PT_ Instale dois parafusos no lado oposto ao ponto de fixação temporária anterior.

DE_ Befestigen Sie zwei Schrauben auf der Seite gegenüber dem zuvor provisorisch angebrachten Befestigungspunkt.

IT_ Installare due viti sul lato opposto al punto di fissaggio provvisorio precedente.

EN_ Remove the temporary screws and re-fasten them at the outer overlap.



FR_ Retirez les vis temporaires et revissez-les au niveau du chevauchement extérieur.

ES_ Retire los tornillos temporales y vuelva a fijarlos en el solapamiento exterior.

PT_ Remova os parafusos temporários e volte a apertá-los na sobreposição exterior.

DE_ Entfernen Sie die provisorischen Schrauben und befestigen Sie sie erneut an der äußeren Überlappung.

IT_ Rimuovere le viti provvisorie e fissarle nuovamente sulla sovrapposizione esterna.

D1	D4	S14
		
x1	x1	x9

EN_ These triangular holes are used as marking holes. During installation, ensure the side with the triangular holes faces upward.

FR_ Ces trous triangulaires servent de repères. Lors de l'installation, veillez à ce que le côté comportant les trous triangulaires soit orienté vers le haut.

ES_ Estos orificios triangulares se utilizan como orificios de marcado. Durante la instalación, asegúrese de que el lado con los orificios triangulares quede hacia arriba.

PT_ Estes orifícios triangulares são utilizados como orifícios de marcação. Durante a instalação, certifique-se de que o lado com os orifícios triangulares fica virado para cima.

DE_ Diese dreieckigen Löcher dienen als Markierungslöcher. Achten Sie bei der Installation darauf, dass die Seite mit den dreieckigen Löchern nach oben zeigt.

IT_ Questi fori triangolari servono come fori di riferimento. Durante l'installazione, assicurarsi che il lato con i fori triangolari sia rivolto verso l'alto.

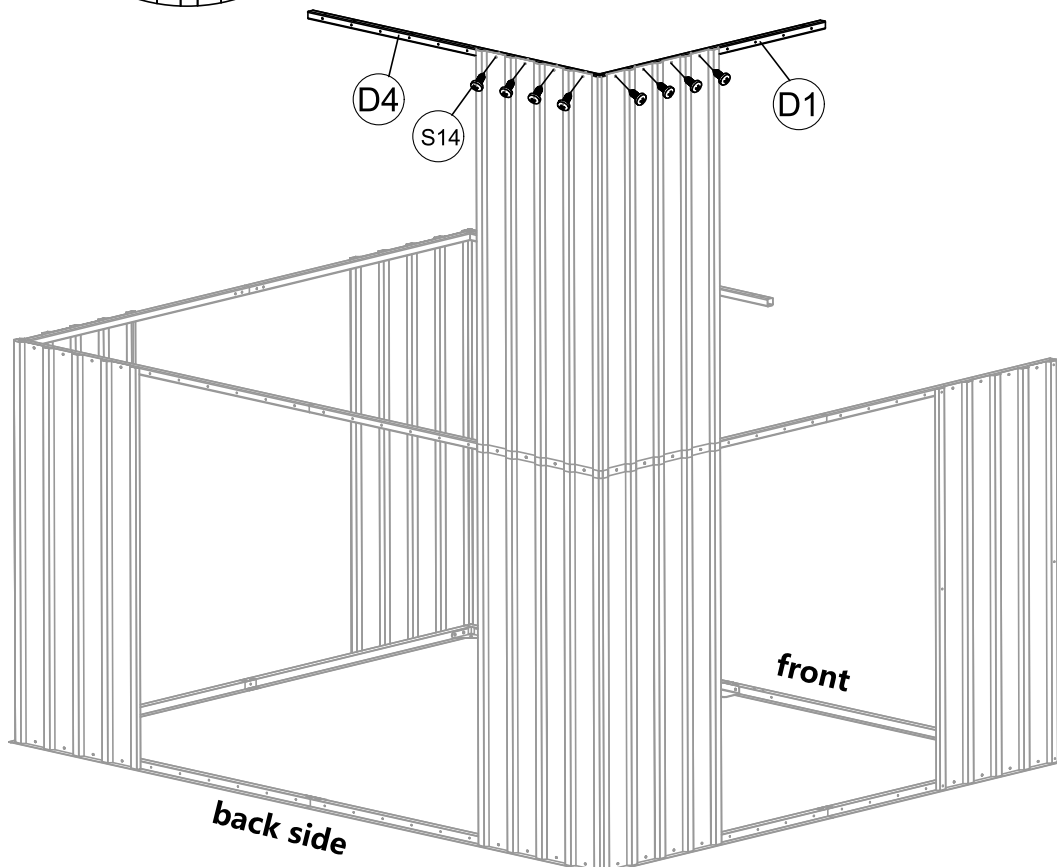
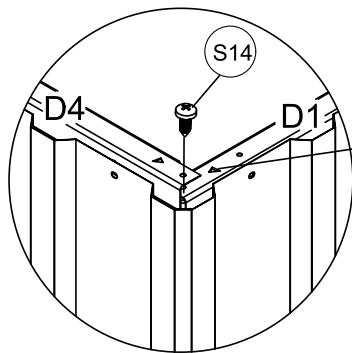

BP1	D2	D3	K21	S14
				
x2	x1	x1	x1	x21

Step 1

Step 2

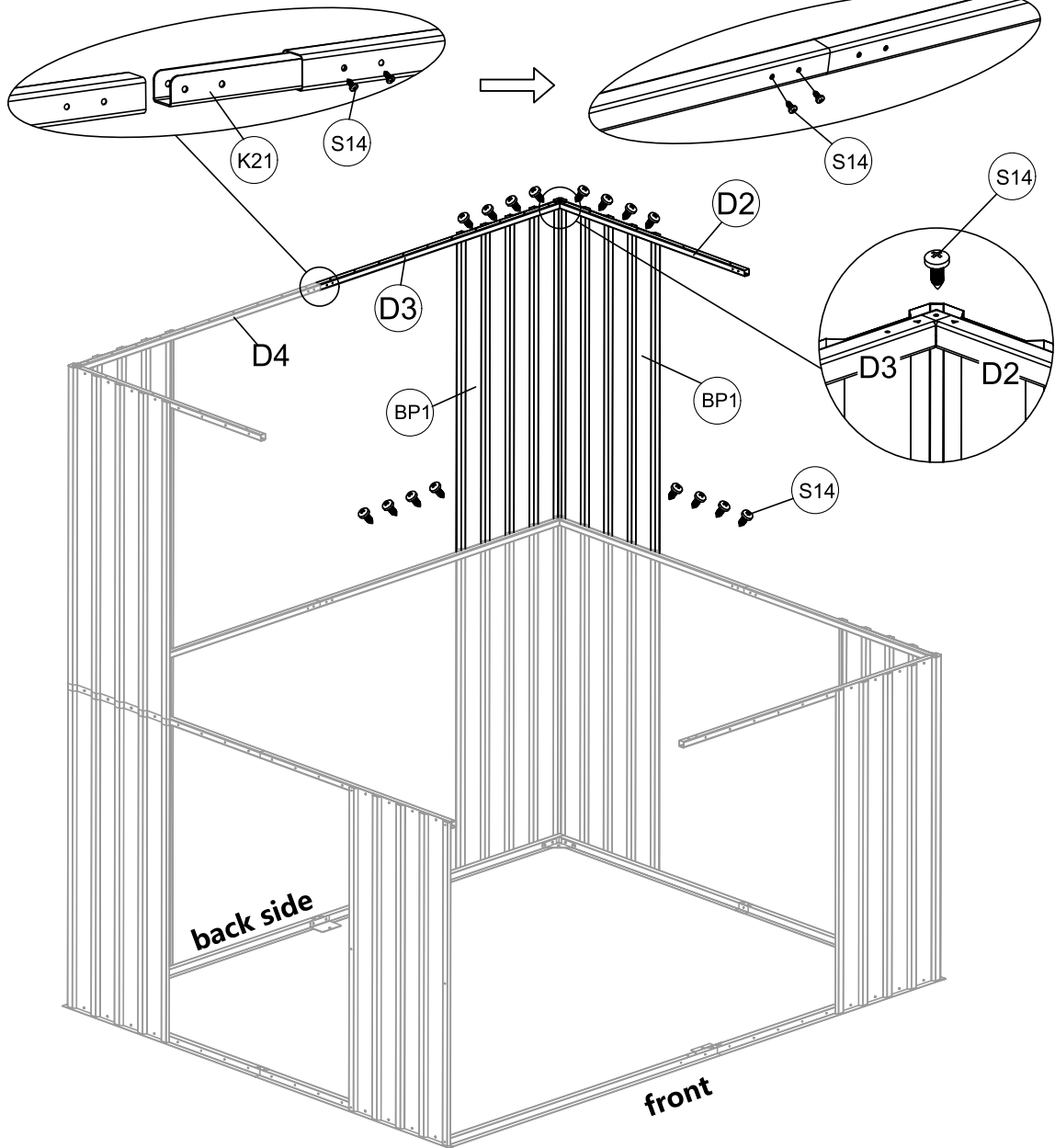

BP1	D1	D6	K21	S14
				
x2	x1	x1	x1	x21

Step 1

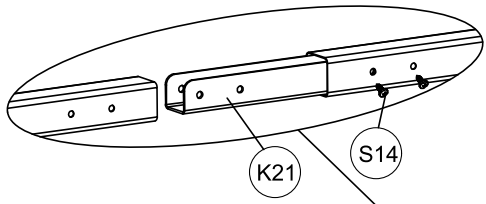

Step 2

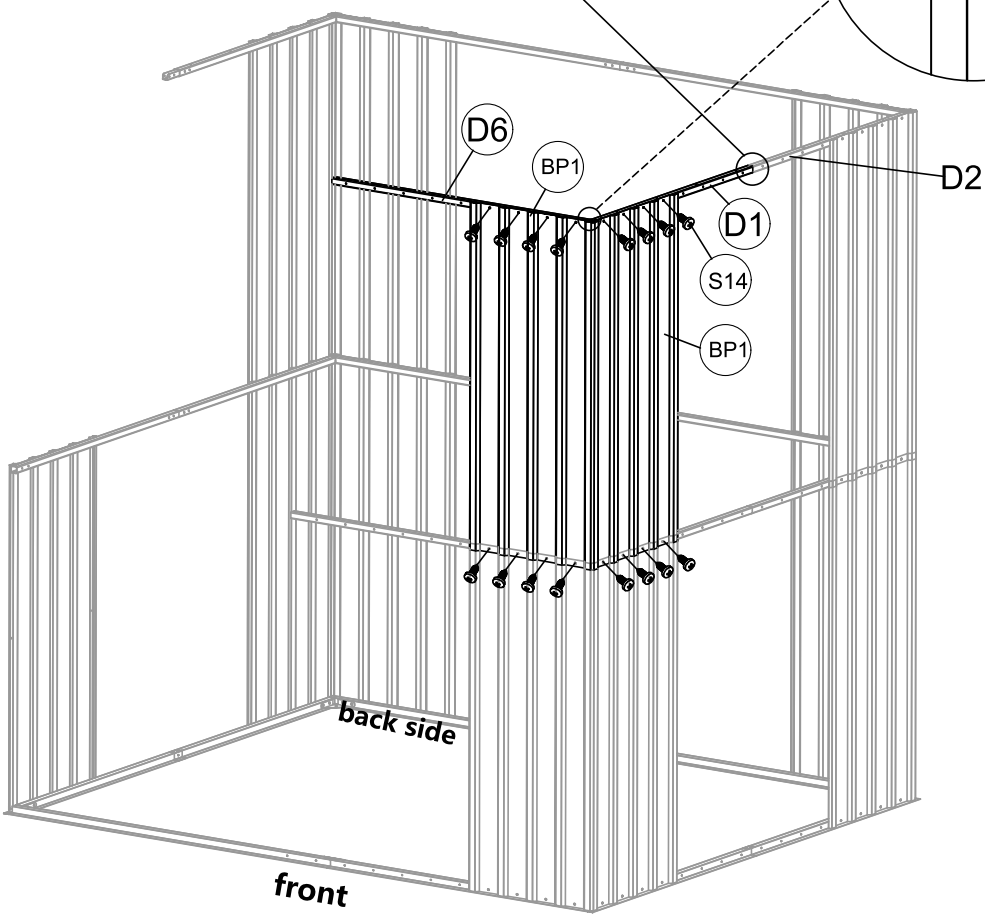
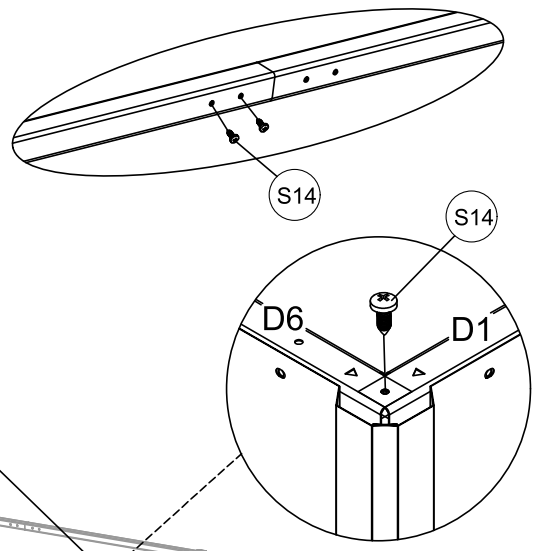



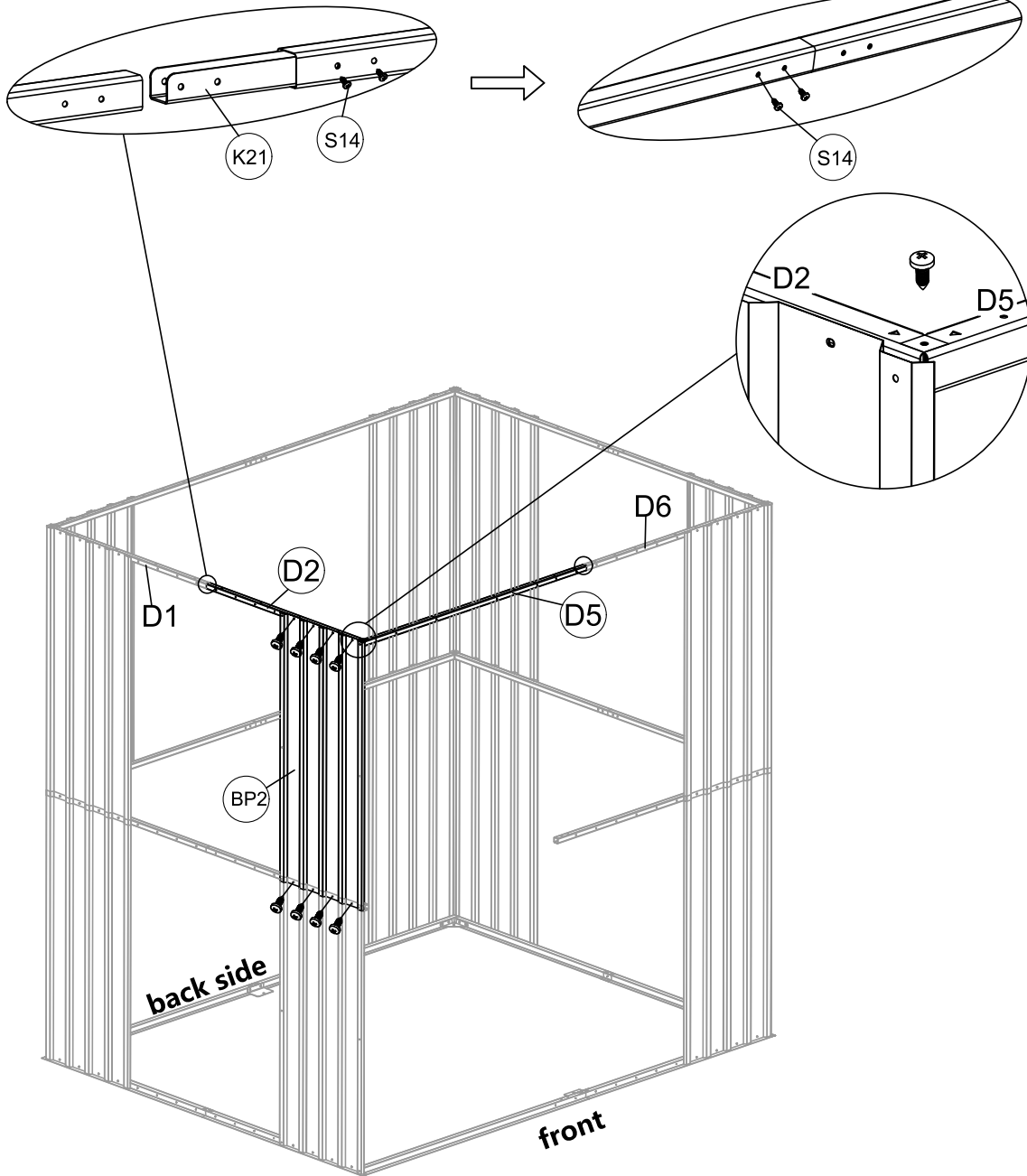

BP2	D2	D5	K21	S14
				
x1	x1	x1	x2	x17

Step 1

Step 2



D12	D13	K21	K18	S14
				
x1	x1	x1	x5	x26

Step 1

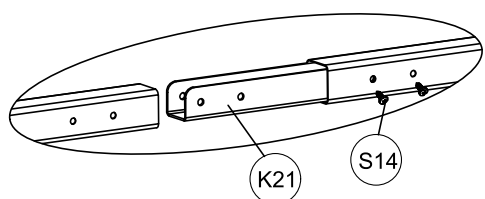

Step 2

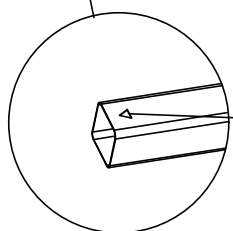
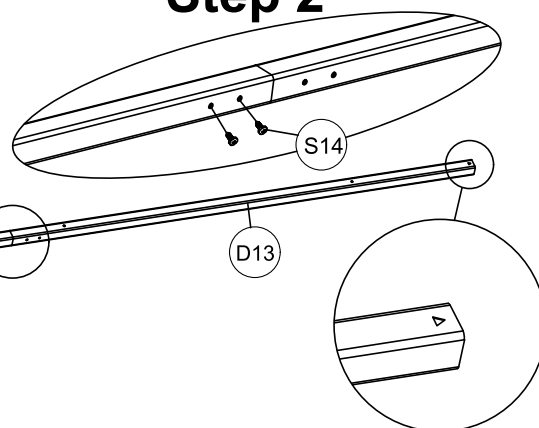

EN_ These triangular holes are used as marking holes. Please note the orientation during installation.

FR_ Ces trous triangulaires servent de repères. Veuillez noter leur orientation lors de l'installation.

ES_ Estos orificios triangulares se utilizan como orificios de marcado. Tenga en cuenta la orientación durante la instalación.

PT_ Estes orifícios triangulares são utilizados como orifícios de marcação. Tenha em atenção a orientação durante a instalação.

DE_ Diese dreieckigen Löcher dienen als Markierungslöcher. Bitte beachten Sie bei der Installation die Ausrichtung.

IT_ Questi fori triangolari servono come fori di riferimento.

Prestare attenzione all'orientamento durante l'installazione.

EN_ These triangular holes are used as marking holes. Please note the orientation during installation.

FR_ Ces trous triangulaires servent de repères. Veuillez noter leur orientation lors de l'installation.

ES_ Estos orificios triangulares se utilizan como orificios de marcado. Tenga en cuenta la orientación durante la instalación.

PT_ Estes orifícios triangulares são utilizados como orifícios de marcação. Tenha em atenção a orientação durante a instalação.

DE_ Diese dreieckigen Löcher dienen als Markierungslöcher. Bitte beachten Sie bei der Installation die Ausrichtung.

IT_ Questi fori triangolari servono come fori di riferimento. Prestare attenzione all'orientamento durante l'installazione.

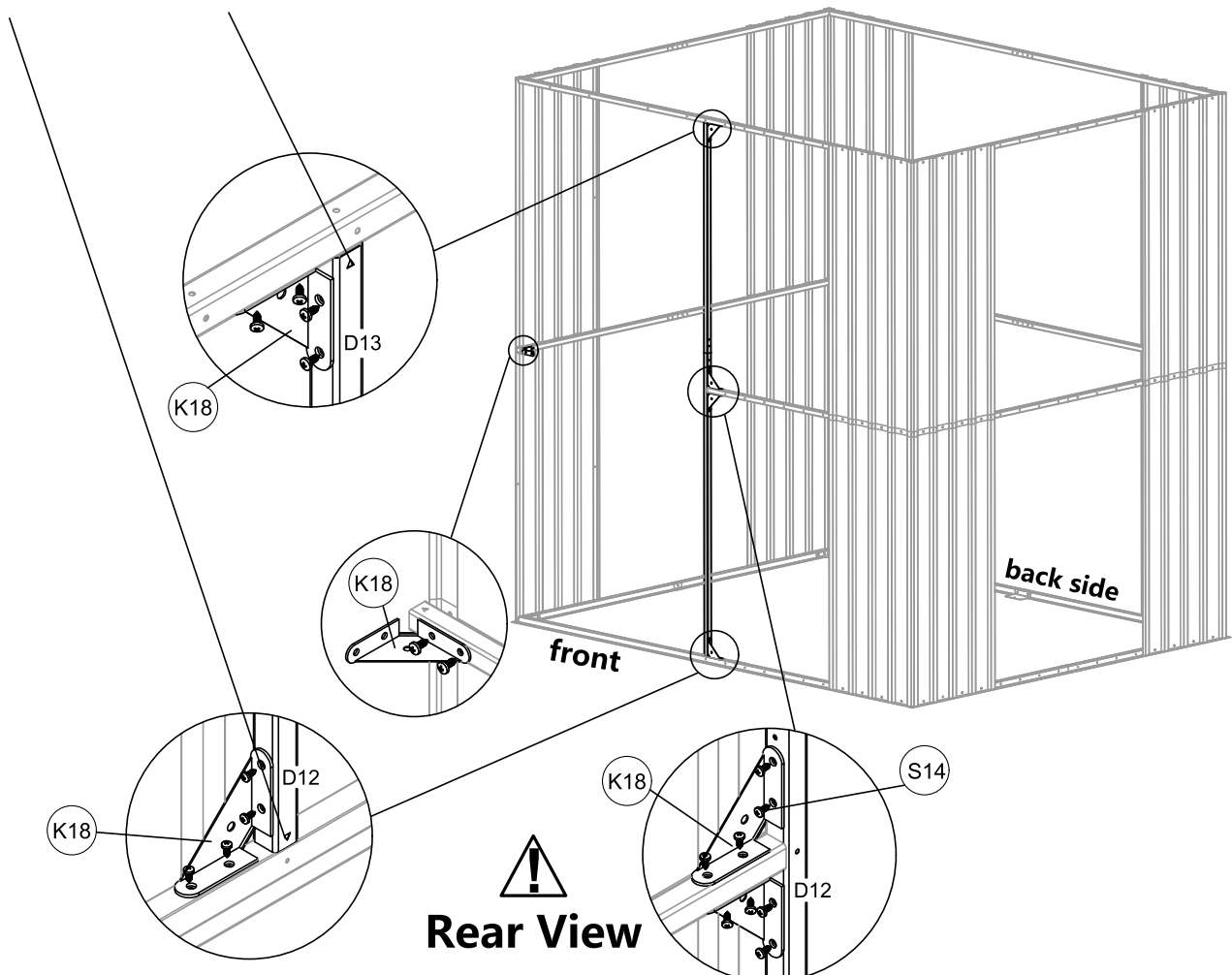

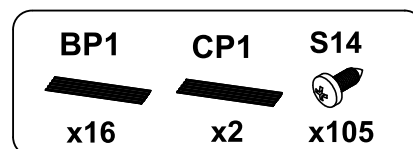

EN_ This step requires installing all wall panels using the established method. For the LOWER panels:

- a. At the foundation connection: Install and fully tighten all screws.2.
- b. At the frame connection: Install one temporary screw per panel.

For the UPPER panels:

- a. Install two permanent screws.
- b. Remove the temporary screw from the lower panel.
- c. Install and fully tighten all remaining screws.

FR_ Cette étape nécessite l'installation de tous les panneaux muraux selon la méthode établie. Pour les panneaux INFÉRIEURS :

- a. Au niveau de la connexion à la fondation : installez et serrez complètement toutes les vis.2.
- b. Au niveau de la connexion au cadre : installez une vis temporaire par panneau.

Pour les panneaux SUPÉRIEURS :

- a. Installez deux vis permanentes.
- b. Retirez la vis temporaire du panneau inférieur.
- c. Installez et serrez complètement toutes les vis restantes.

ES_ Este paso requiere instalar todos los paneles de pared utilizando el método establecido. Para los paneles INFERIORES:

- a. En la conexión con la base: instale y apriete completamente todos los tornillos.2.
- b. En la conexión con el marco: instale un tornillo temporal por panel.

Para los paneles SUPERIORES:

- a. Instale dos tornillos permanentes.
- b. Retire el tornillo temporal del panel inferior.
- c. Instale y apriete completamente todos los tornillos restantes.

PT_ Esta etapa requer a instalação de todos os painéis de parede utilizando o método estabelecido. Para os painéis INFERIORES:

- a. Na ligação à fundação: instale e aperte totalmente todos os parafusos.2.
- b. Na ligação à estrutura: instale um parafuso temporário por painel.

Para os painéis SUPERIORES:

- a. Instale dois parafusos permanentes.
- b. Remova o parafuso temporário do painel inferior.
- c. Instale e aperte totalmente todos os parafusos restantes.

DE_ Bei diesem Schritt müssen alle Wandpaneele nach der festgelegten Methode installiert werden. Für die UNTEREN Paneele:

- a. An der Fundamentverbindung: Alle Schrauben anbringen und festziehen.2.
- b. An der Rahmenverbindung: Pro Paneel eine provisorische Schraube anbringen.

Für die OBEREN Paneele:

- a. Zwei permanente Schrauben anbringen.
- b. Die provisorische Schraube vom unteren Paneel entfernen.
- c. Alle übrigen Schrauben anbringen und festziehen.

IT_ Questo passaggio richiede l'installazione di tutti i pannelli a parete utilizzando il metodo stabilito. Per i pannelli INFERIORI:



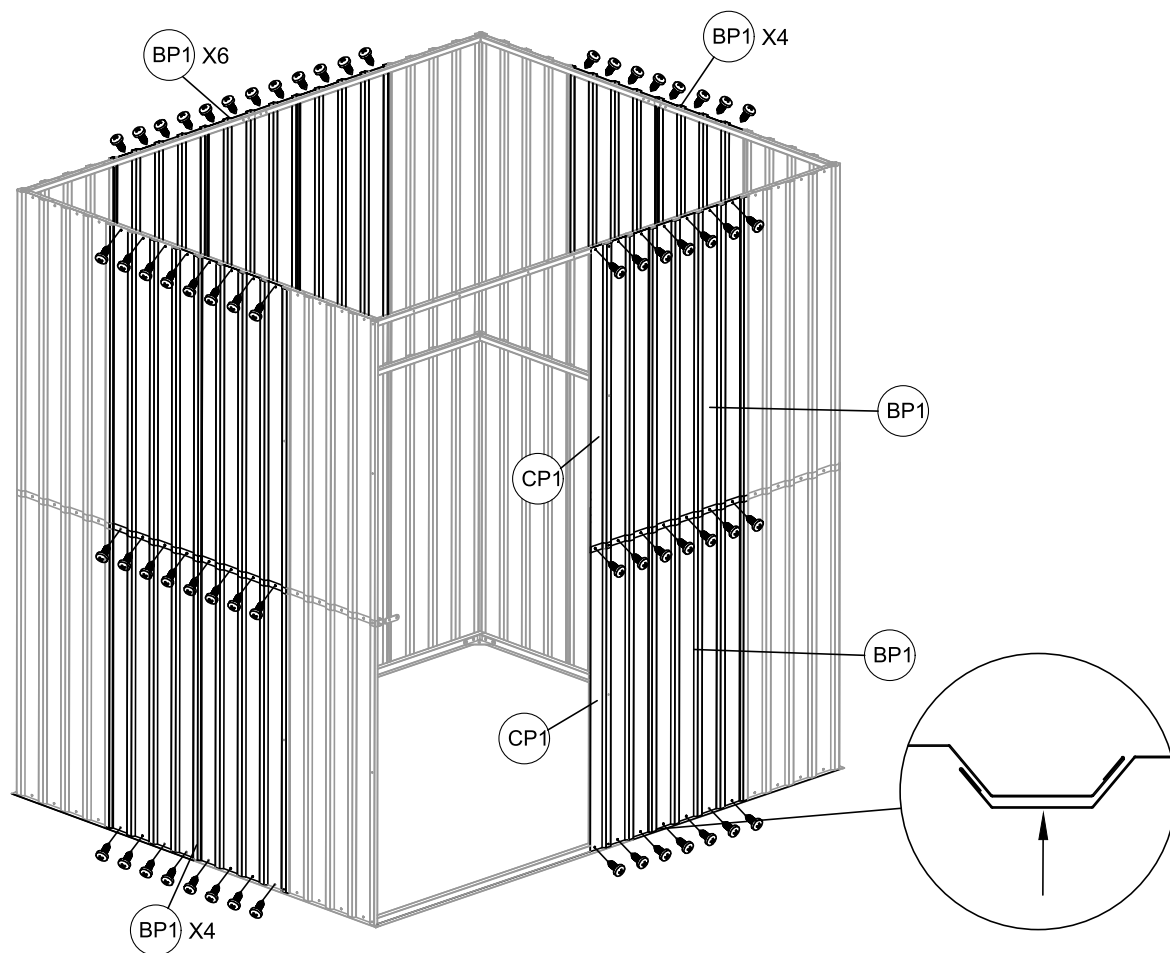

- a. Al collegamento con la fondazione: installare e serrare completamente tutte le viti.2.
- b. Al collegamento con il telaio: installare una vite provvisoria per ogni pannello.

Per i pannelli SUPERIORI:

- a. Installare due viti permanenti.
- b. Rimuovere la vite provvisoria dal pannello inferiore.
- c. Installare e serrare completamente tutte le viti rimanenti.



- EN_** Ensure that the tiles overlap.
- FR_** Assurez-vous que les carreaux se chevauchent.
- ES_** Asegúrese de que las baldosas se superpongan.
- PT_** Certifique-se de que os ladrilhos se sobreponham.
- DE_** Stellen Sie sicher, dass sich die Fliesen überlappen.
- IT_** Assicurarsi che le piastrelle si sovrappongano.

ZJ1-1	ZJ1-2	ZJ3	S14	S19
				
x1	x1	x1	x15	x2

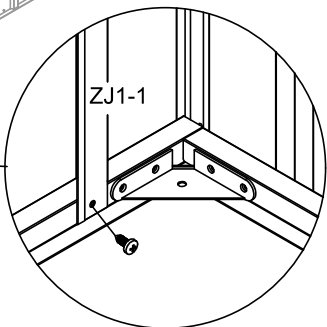
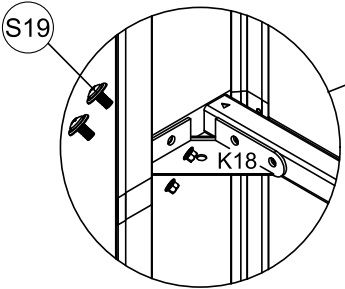
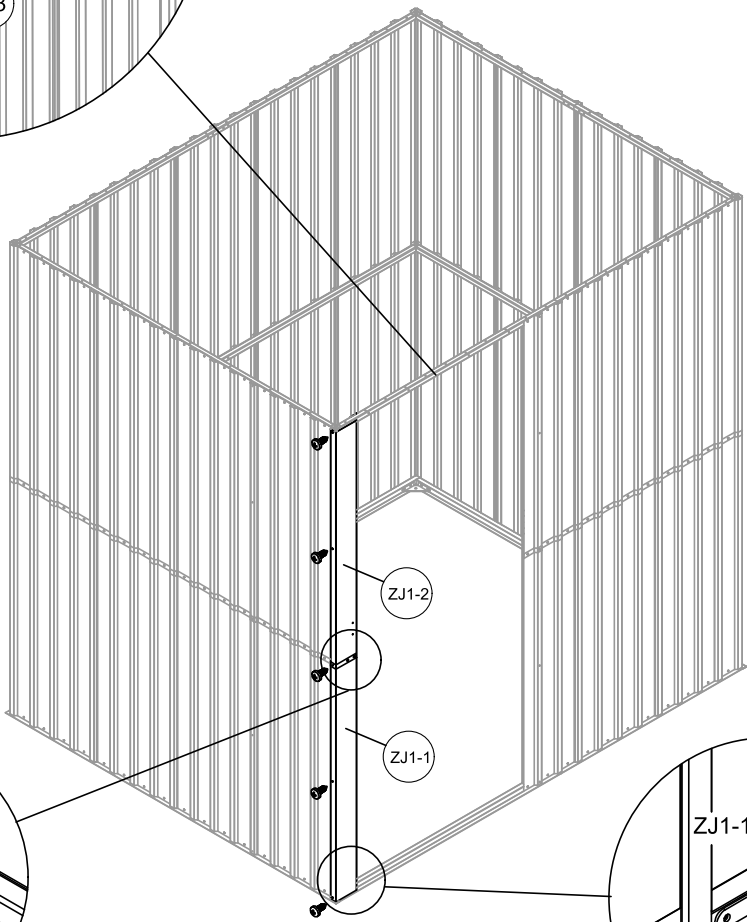
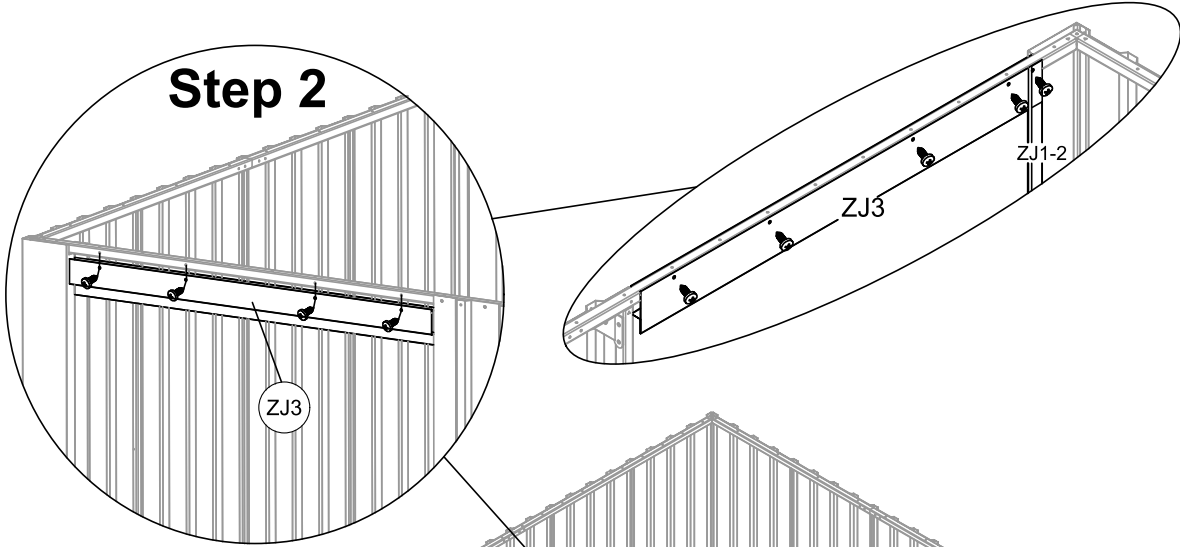

ZJ2-1  x1	ZJ2-2  x1	S14  x12
---	---	--

Step 1

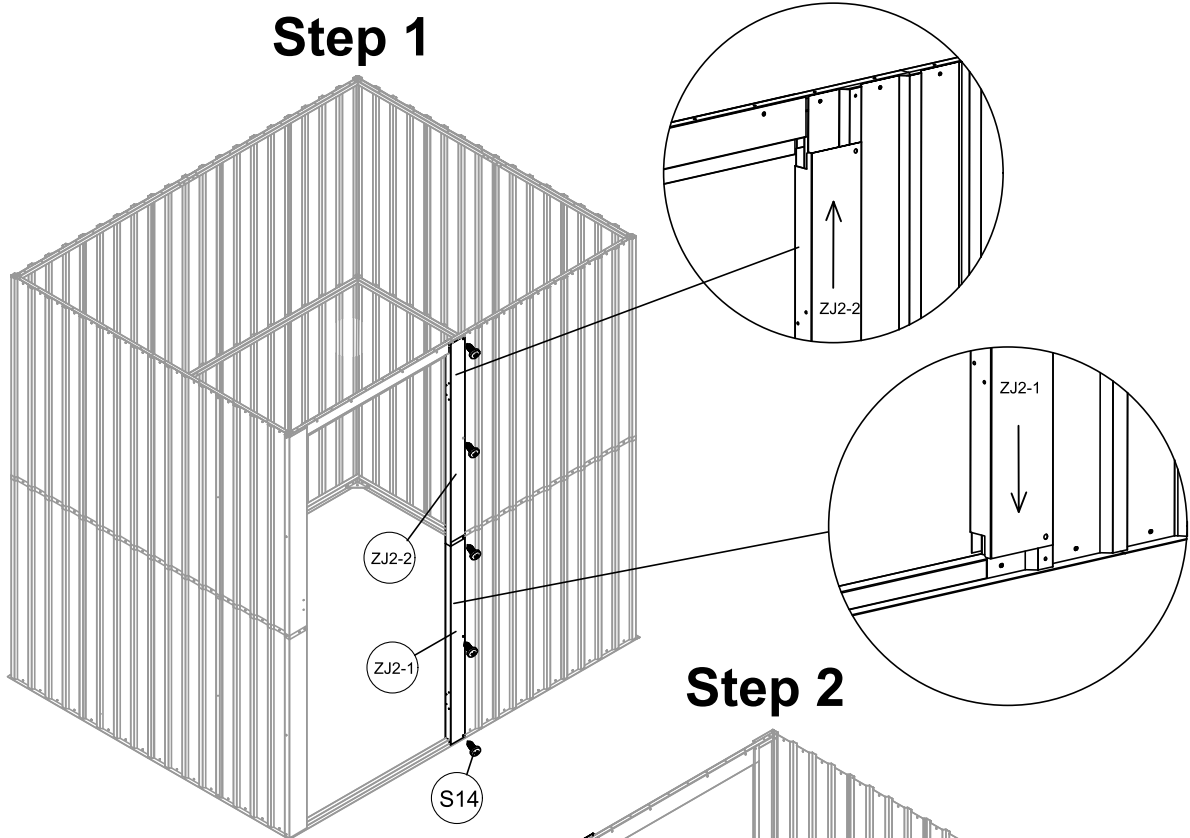

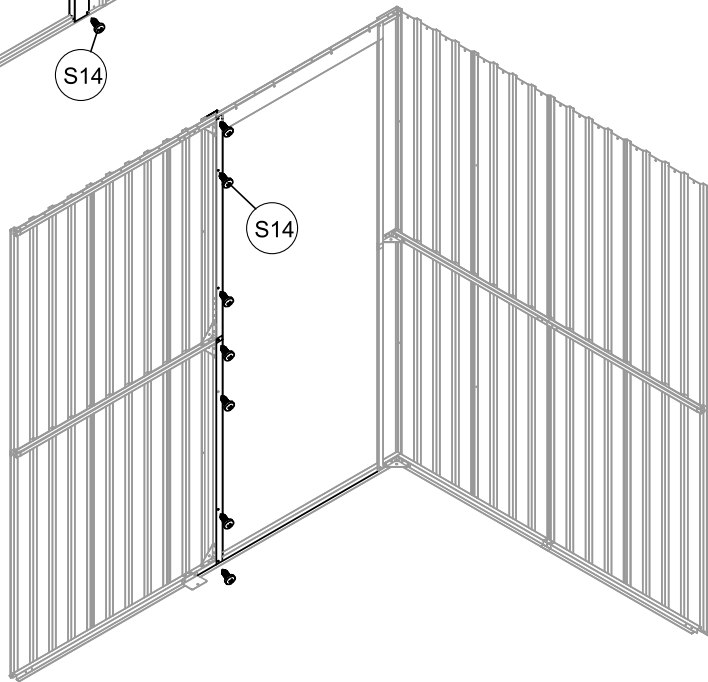

Step 2

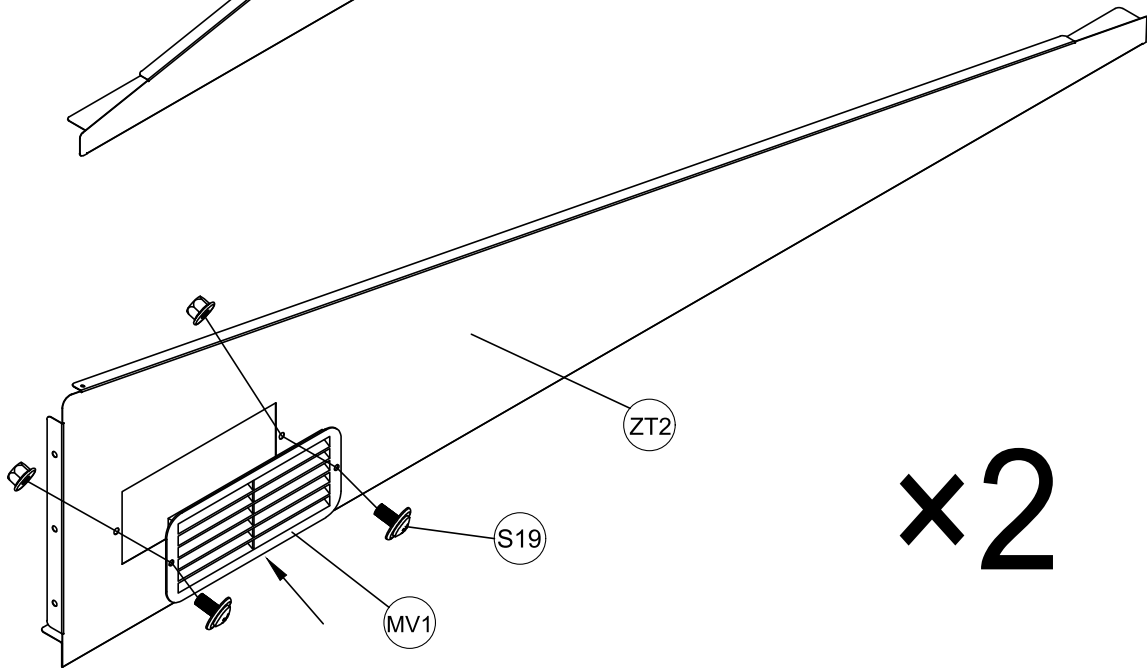
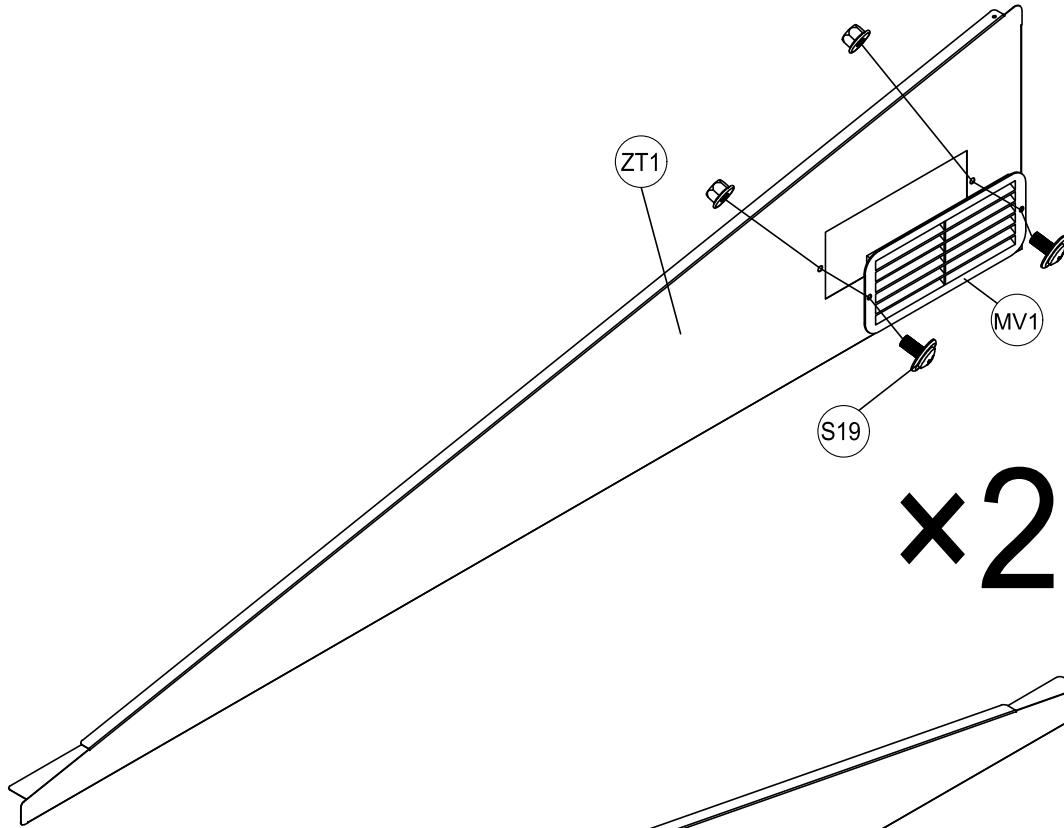

ZT1  x2	ZT2  x2	S19  x8	MV1  x4
---	---	---	---



0

- | | | |
|---|---|---|
| D7 | S14 | S32 |
|  |  |  |
| x4 | x16 | x4 |

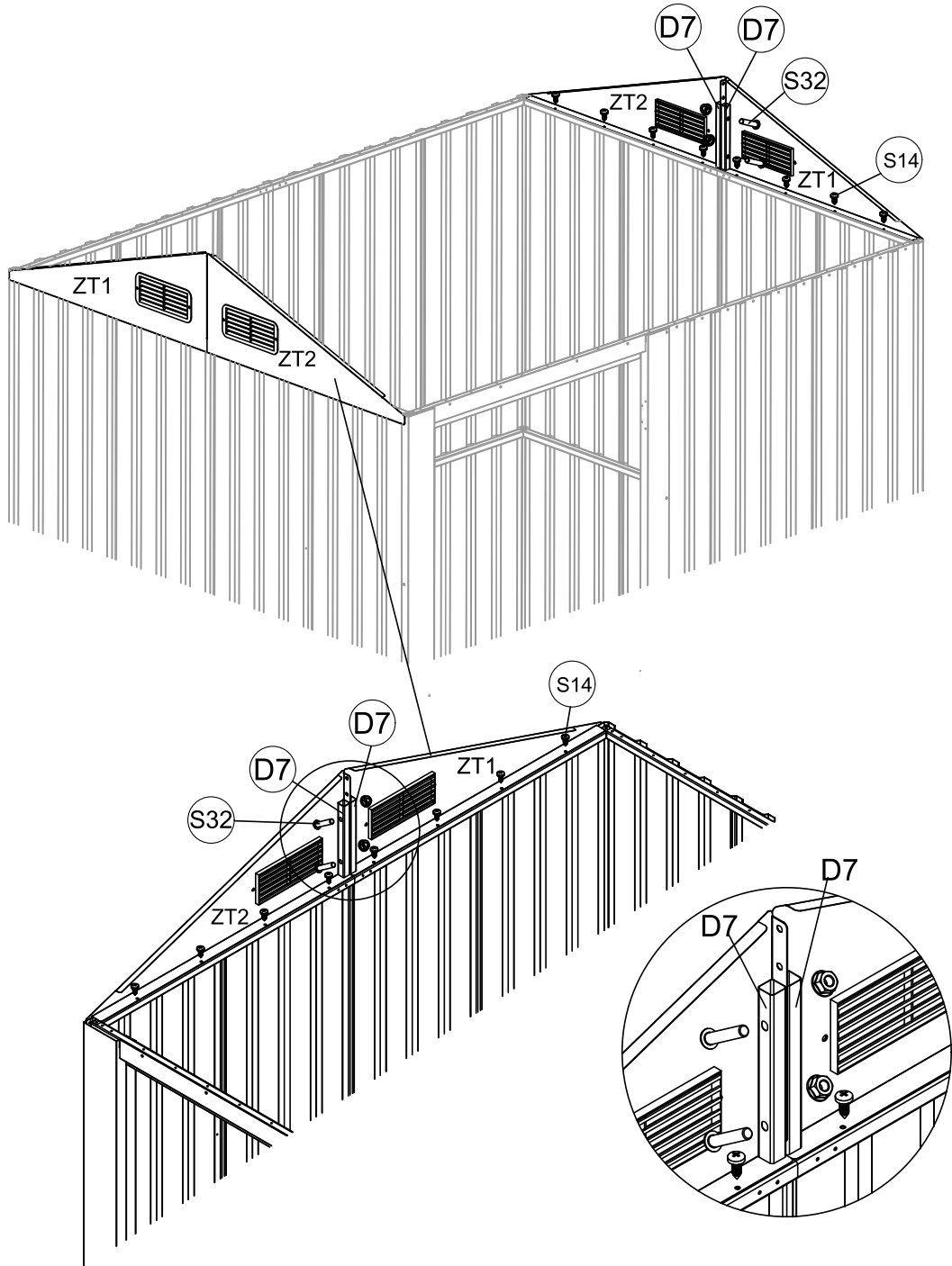

BC1 [C-Profile] x2	BC2 [C-Profile] x2	BC3 [C-Profile] x2	S19 [Screw] x12
---------------------------------	---------------------------------	---------------------------------	------------------------------

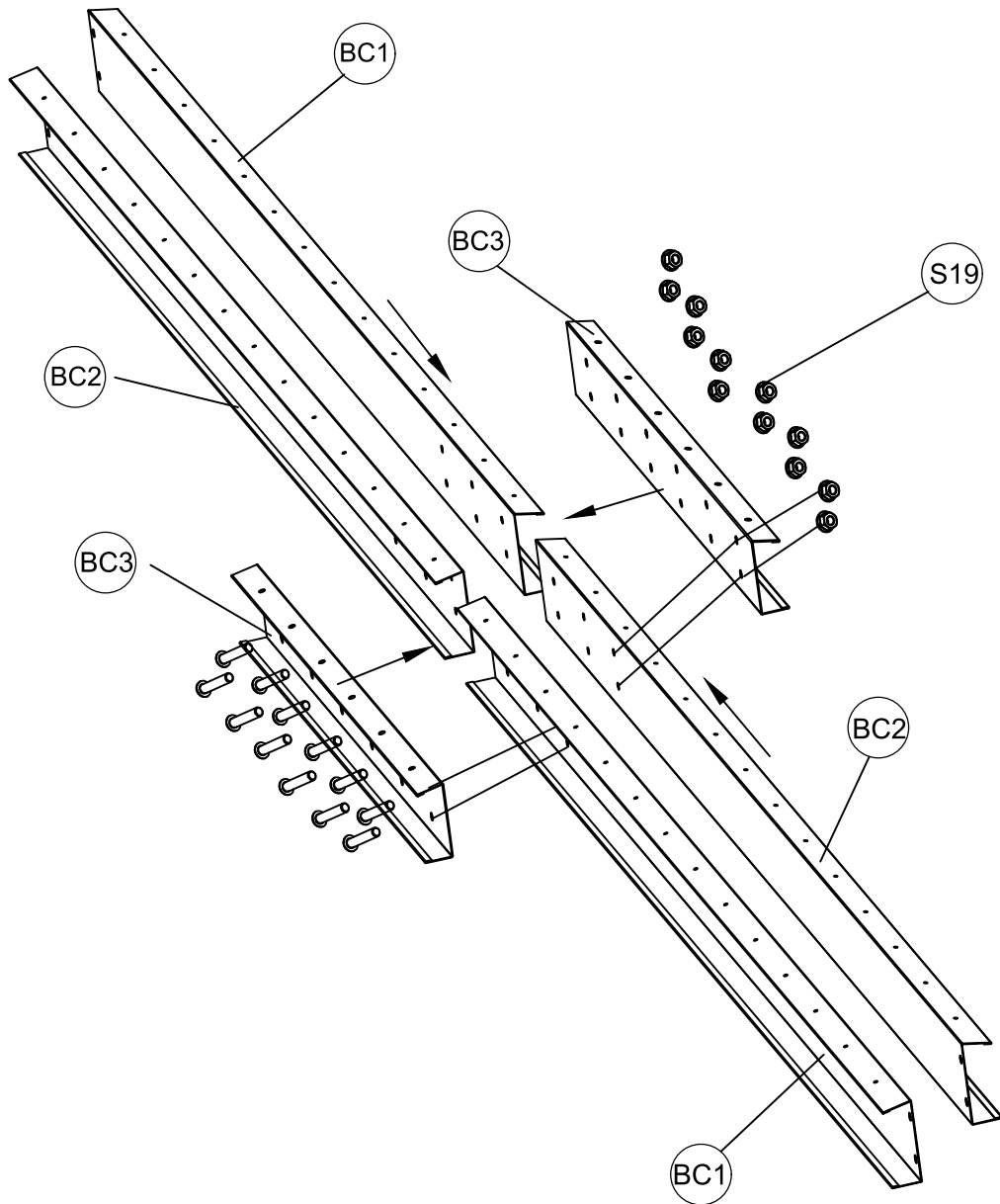

S19



x4

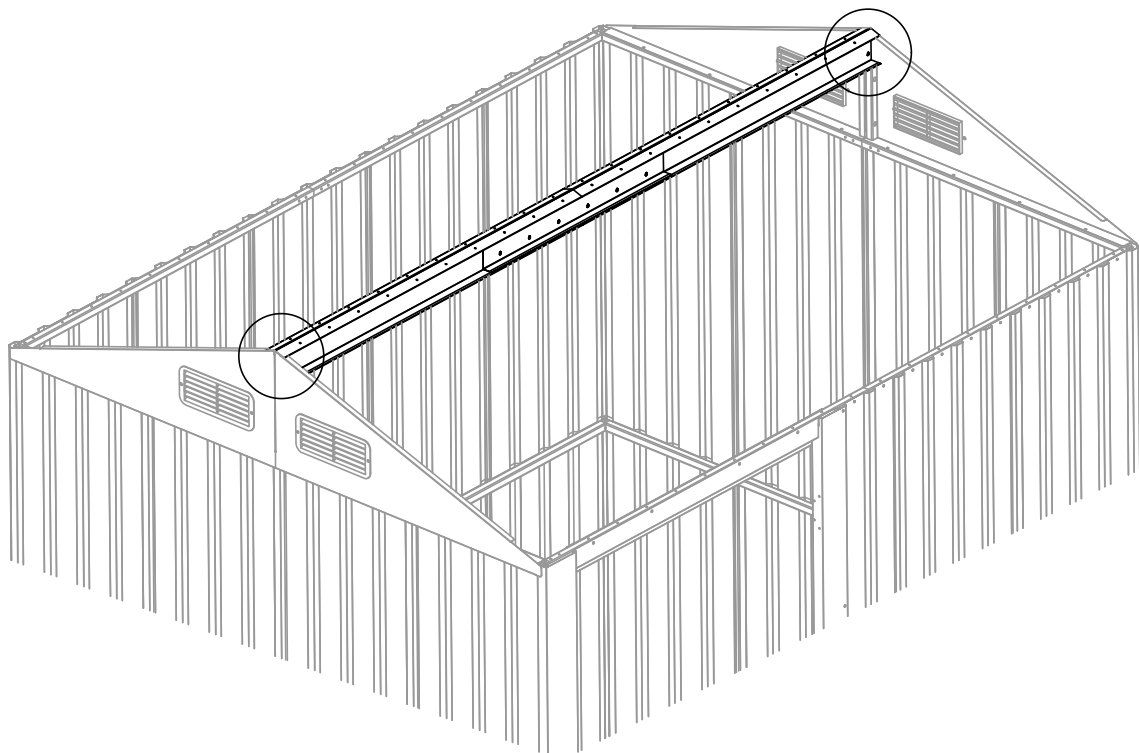
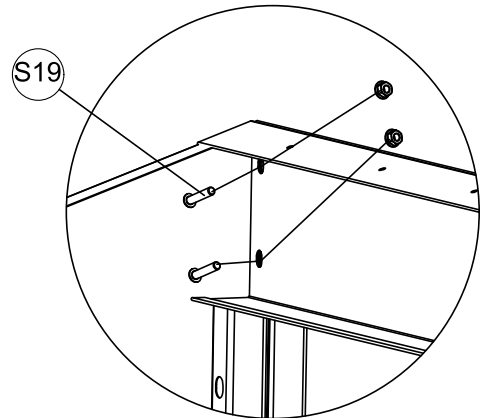
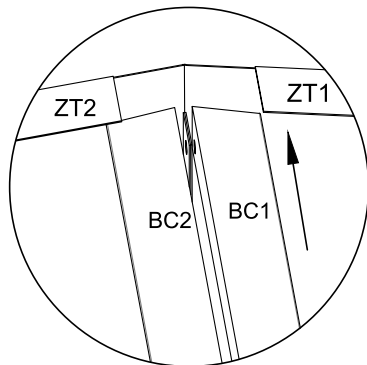

BP11  x4	ZR1  x1	S14  x34	M3  x34
--	---	--	---

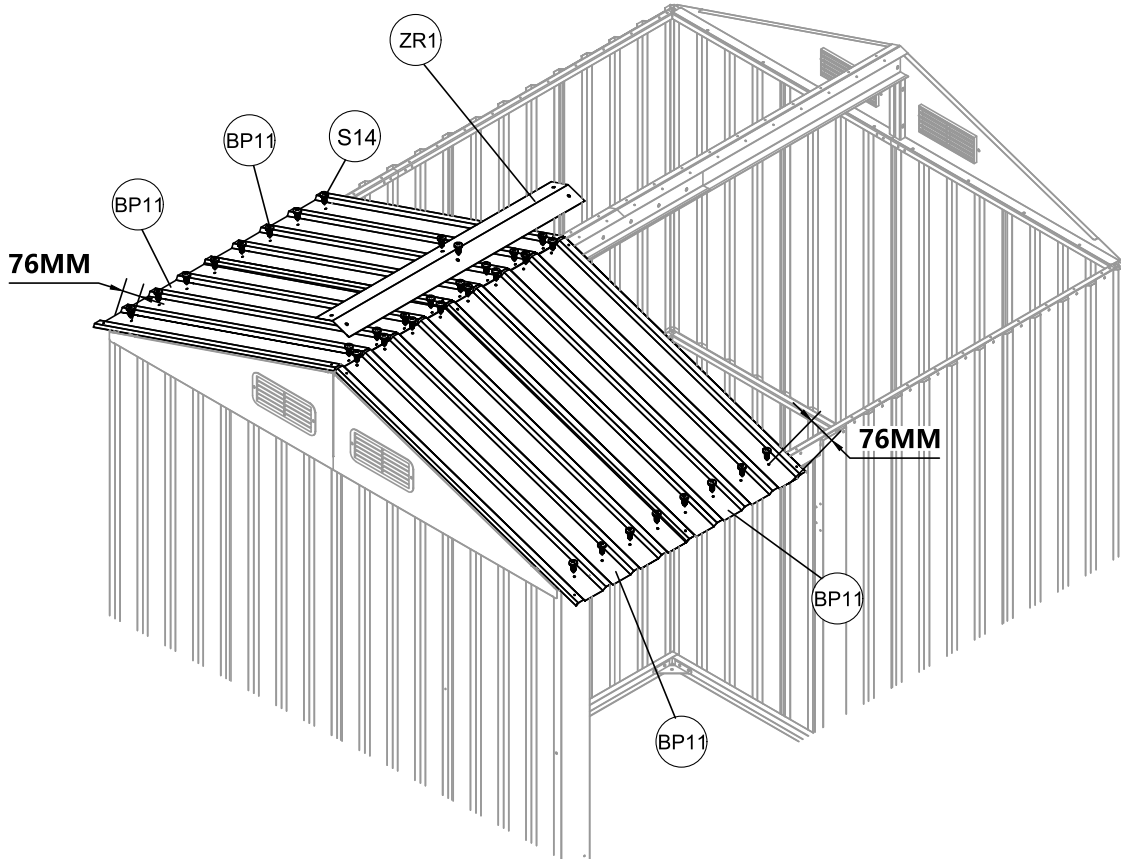
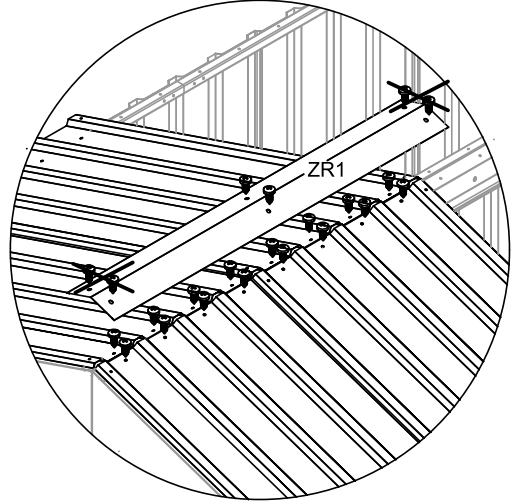
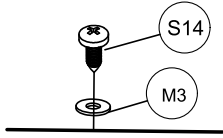



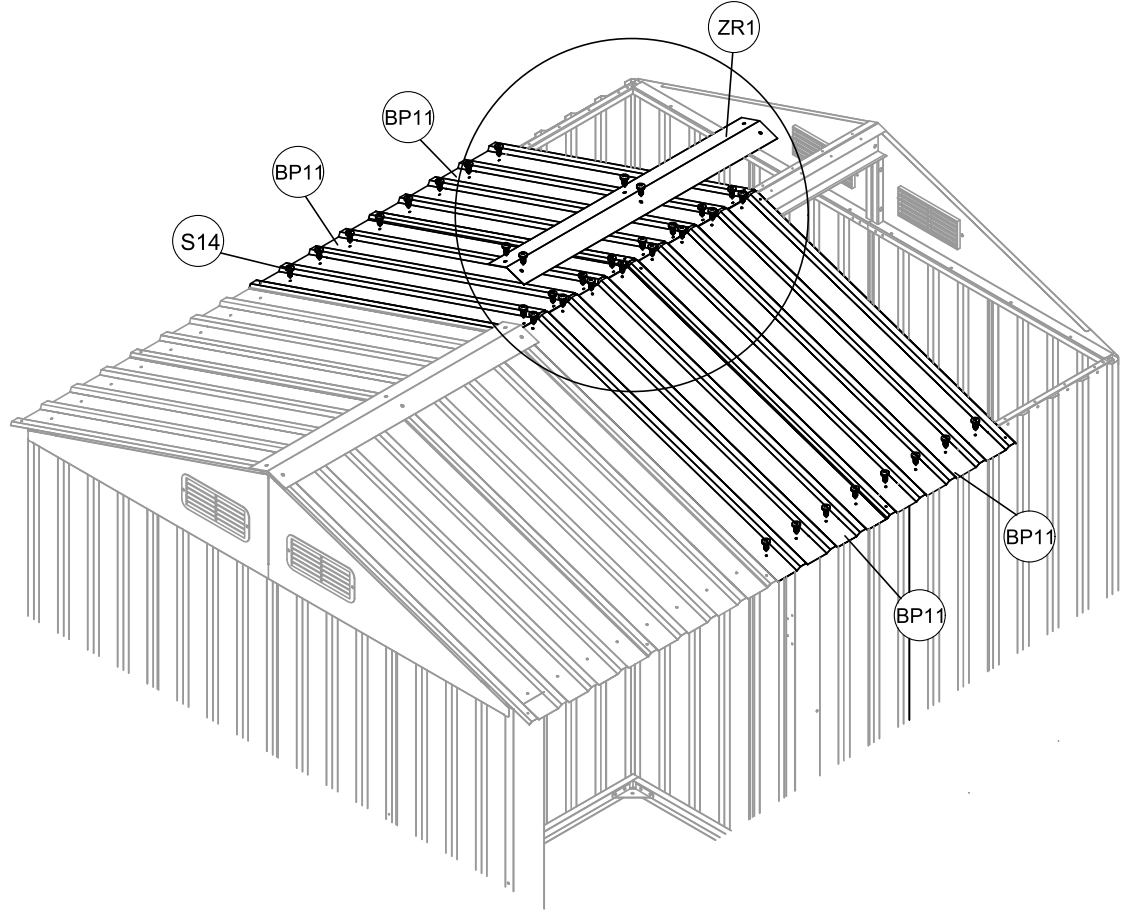
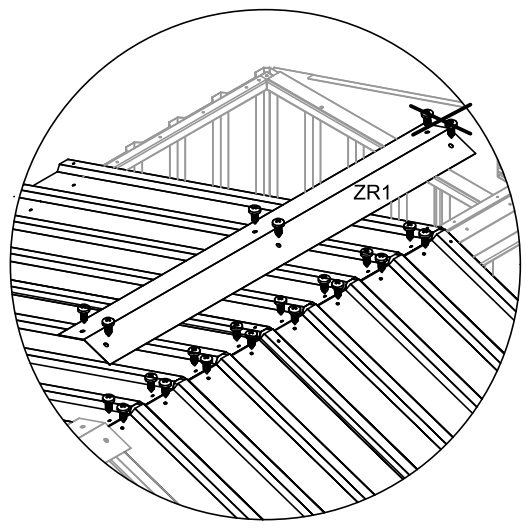
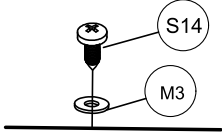

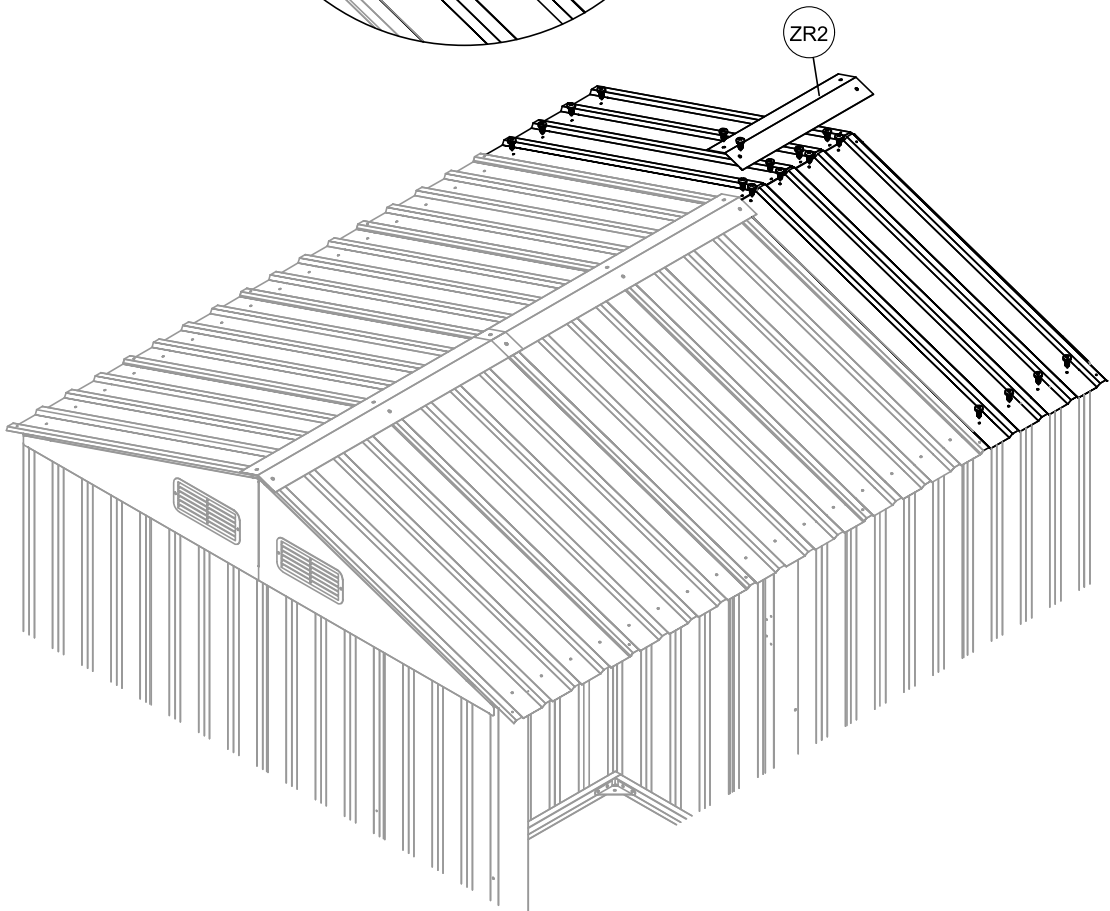
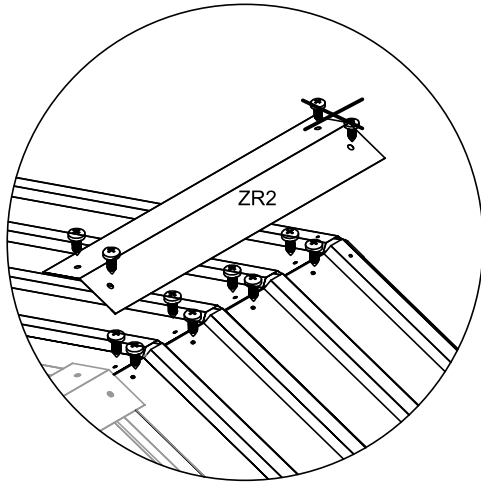
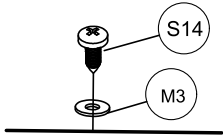

BP11  x4	ZR1  x1	S14  x36	M3  x36
--	---	--	---









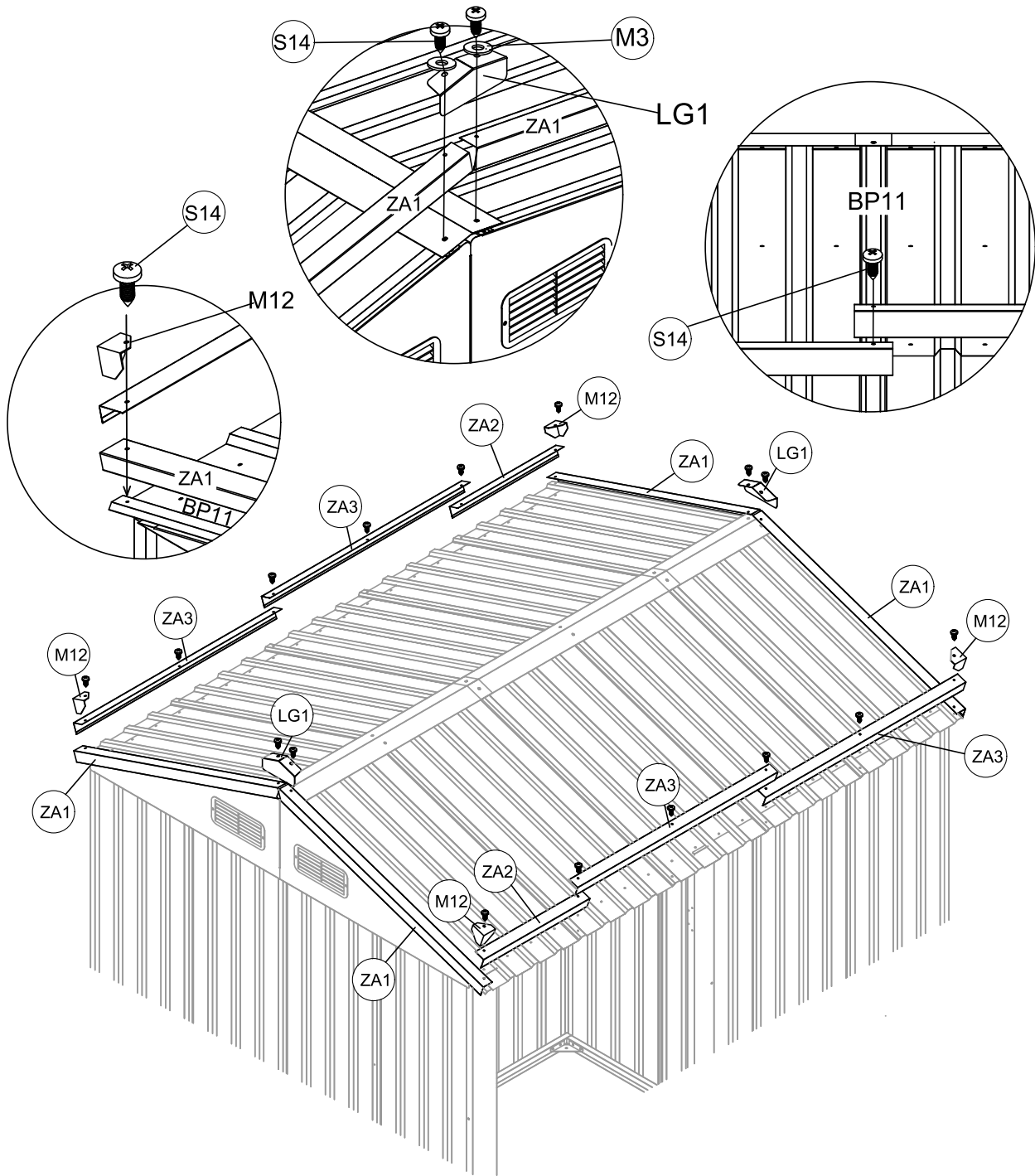



BP11  x2	ZR2  x1	S14  x18	M3  x18
--	---	--	---



ZA1  x4	ZA2  x2	ZA3  x4	LG1  x2	M12  x4	S14  x16	M3  x4
---	---	---	---	---	--	--



BPD1-1	BPD1-2	BPD2-1	BPD2-2	ZD1	ZD2-1	ZD2-2	ZD3-1	ZD3-2	S14
									
x1	x1	x1	x1	x2	x1	x1	x1	x1	x12



EN_ Perform a trial assembly first. Ensure all holes are aligned and parts are correctly positioned before tightening the screws for this step.

FR_ Effectuez d'abord un assemblage d'essai. Assurez-vous que tous les trous sont alignés et que les pièces sont correctement positionnées avant de serrer les vis pour cette étape.

ES_ Realice primero un montaje de prueba. Asegúrese de que todos los orificios estén alineados y las piezas estén correctamente colocadas antes de apretar los tornillos en este paso.

PT_ Faça primeiro uma montagem de teste. Certifique-se de que todos os orifícios estão alinhados e as peças estão posicionadas corretamente antes de apertar os parafusos nesta etapa.

DE_ Führen Sie zunächst eine Probemontage durch. Vergewissern Sie sich, dass alle Löcher ausgerichtet und die Teile korrekt positioniert sind, bevor Sie die Schrauben für diesen Schritt festziehen.

IT_ Eseguire prima un assemblaggio di prova. Assicurarsi che tutti i fori siano allineati e che le parti siano posizionate correttamente prima di serrare le viti per questo passaggio.

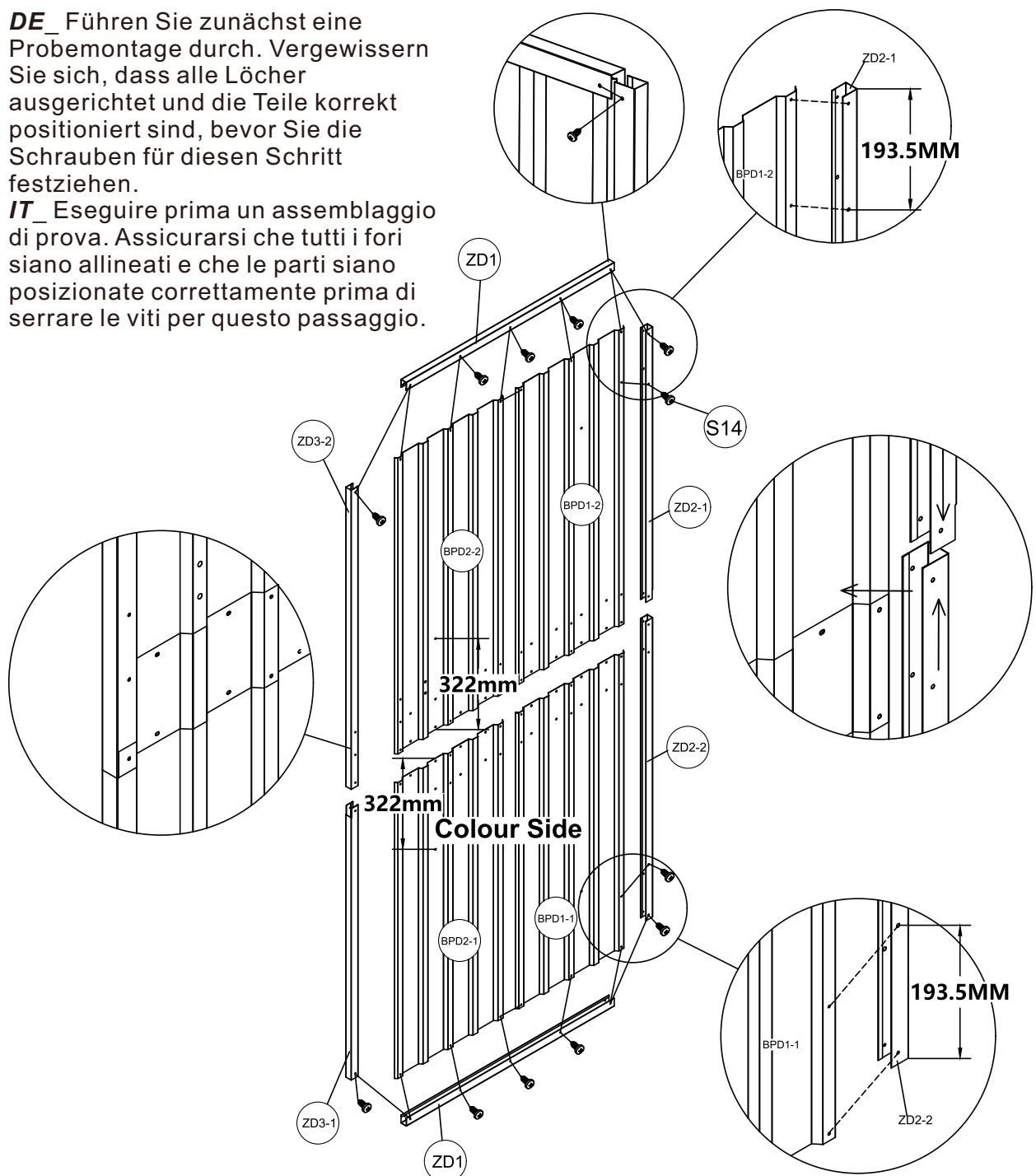

ED1  x2	ED2  x2	S14  x32
---	---	--

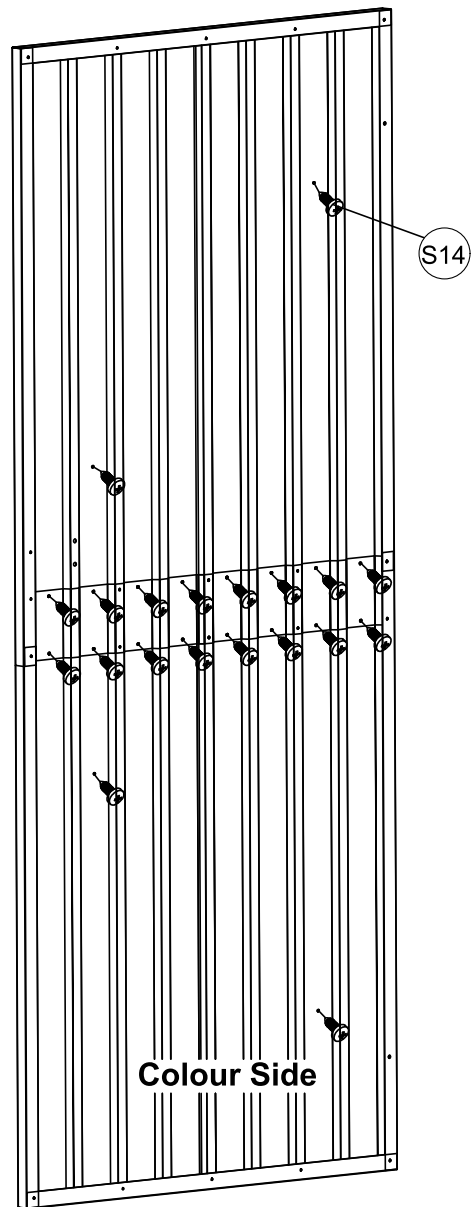
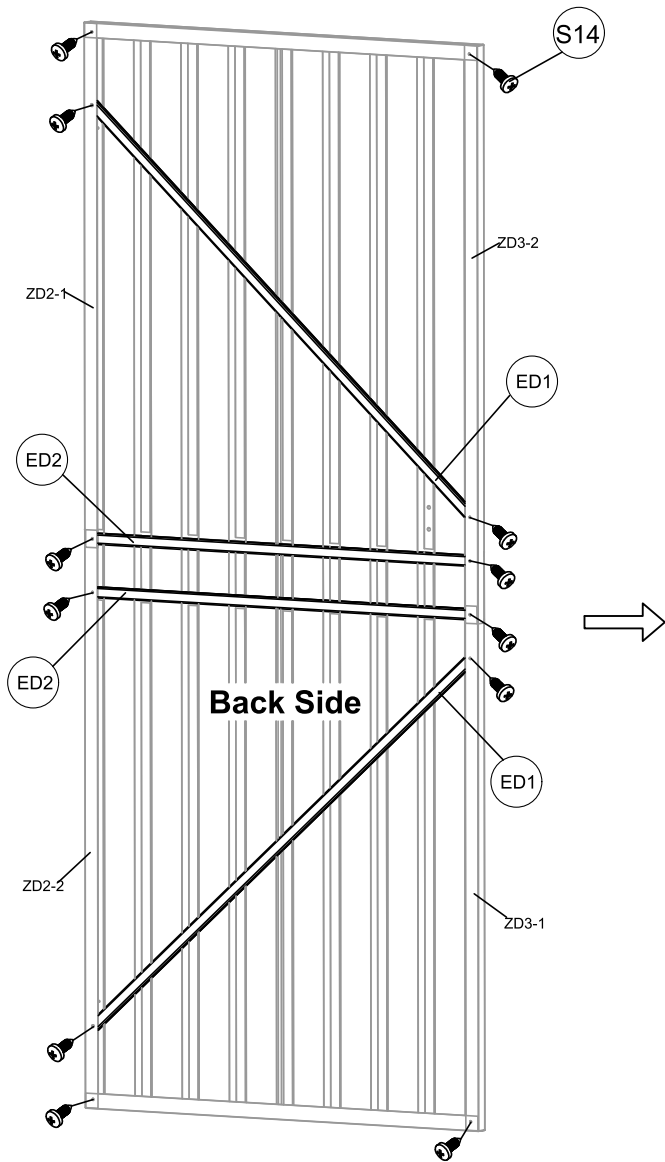

ZD4	K27	S21	S14
			
x1	x2	x8	x10

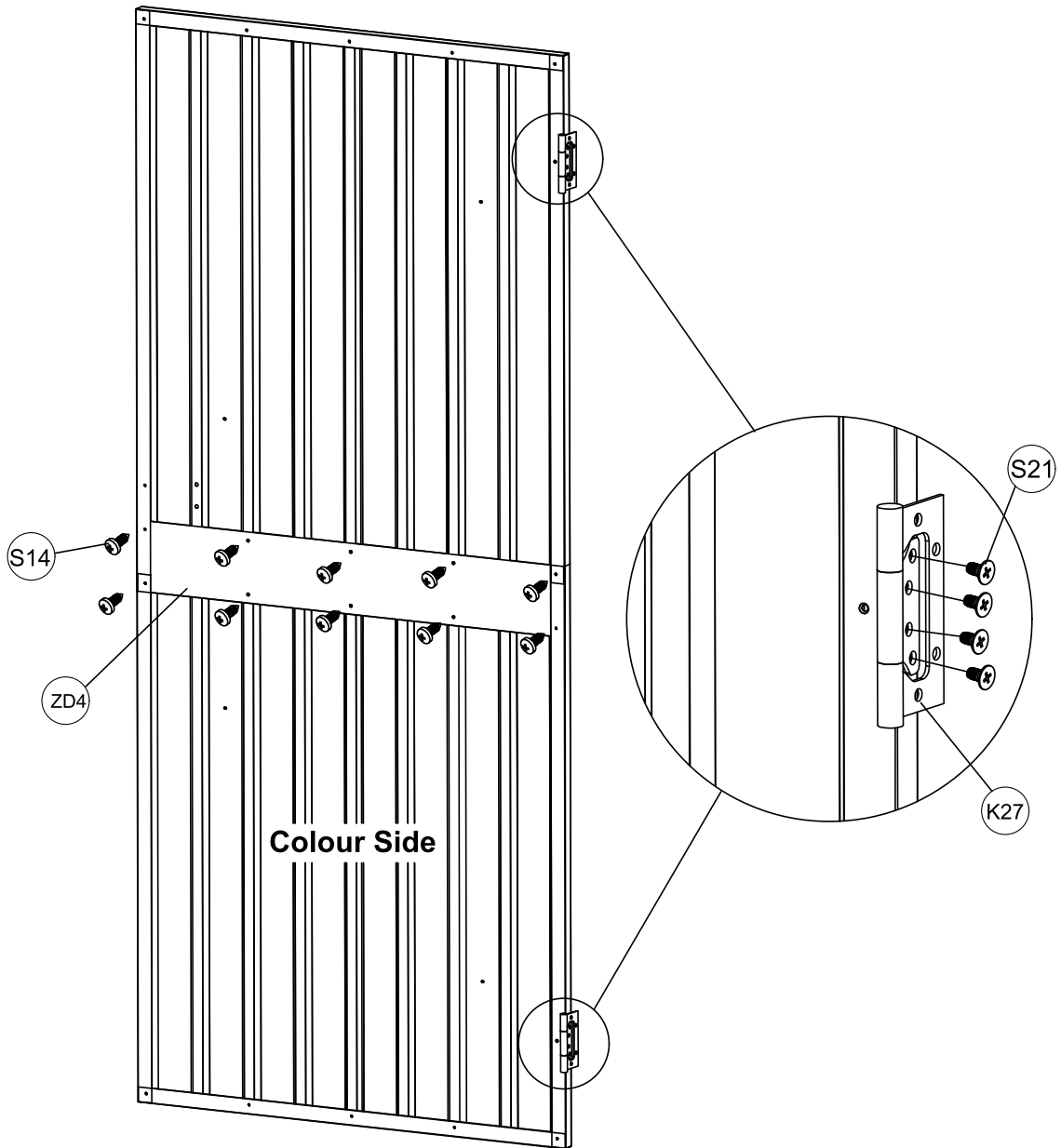

L4



x1

S14



x3

S19



x2

S21



x8

M4



x42

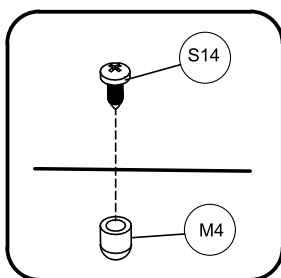

EN_ Put a silicone sheath on the sharp parts.

FR_ Placez une gaine en silicone sur les parties tranchantes.

ES_ Cubre las partes afiladas con una funda de silicona.

PT_ Coloque uma capa de silicone nas partes afiladas.

DE_ Befestigen Sie eine Silikonhülle an den scharfen Teilen.

IT_ Metti una guaina in silicone sulle parti taglienti.

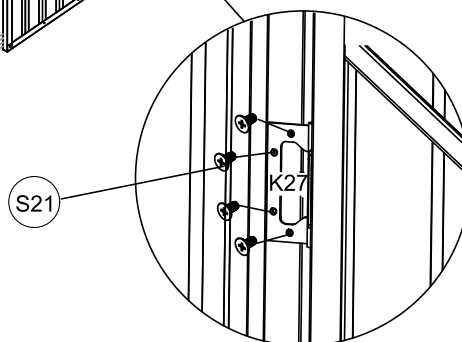
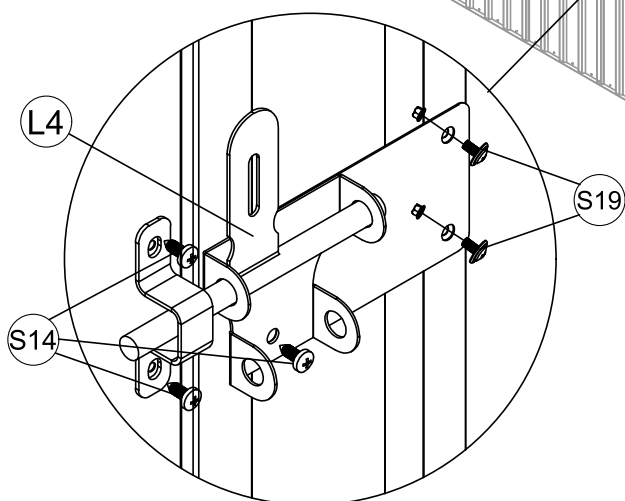
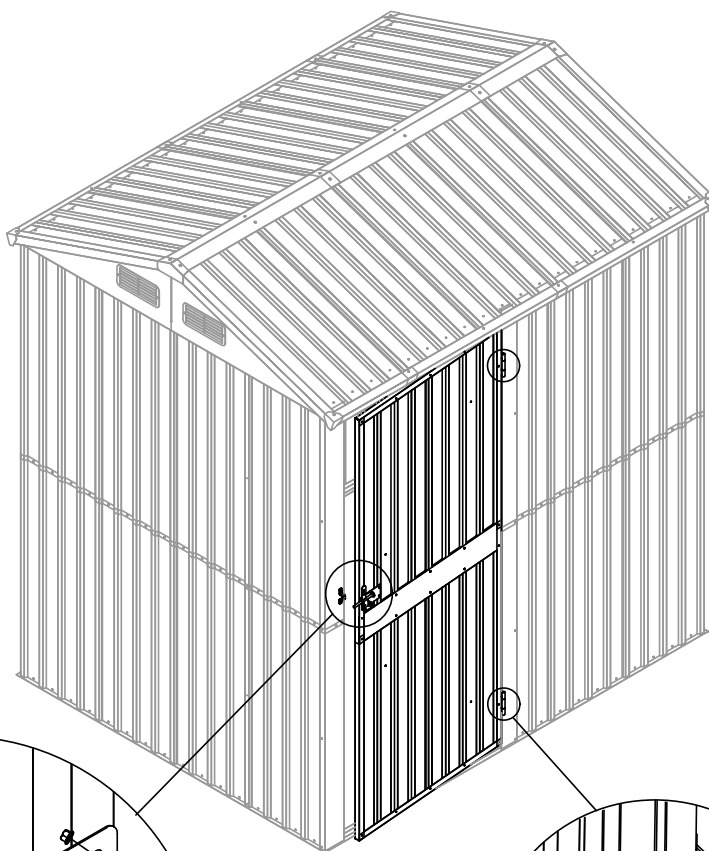

If you have any questions, please contact our customer care center, Our contact details are below:

US

 001-877-644-9366

 customerservice@aosom.com

Imported by Aosom LLC
27150 SW Kinsman Rd Wilsonville, OR 97070 USA
MADE IN CHINA

If you have any questions, please contact our customer care center, Our contact details are below:

CA

 416-792-6088

 customerservice@aosom.ca

Imported by Aosom Canada Inc.
7270 Woodbine Avenue, Unit 307, Markham,
Ontario Canada L3R 4B9
MADE IN CHINA

Si vous avez la moindre question, veuillez contacter notre centre d'assistance à la clientèle, Nos coordonnées sont les suivantes:

 416-792-6088

 customerservice@aosom.ca

Importé par Aosom Canada Inc.
7270 Woodbine Avenue, unité 307,
Markham, Ontario Canada L3R 4B9
FABRIQUÉ EN CHINE

If you have any questions, please contact our customer care center, Our contact details are below:

UK

 0044-800-240-4004

 enquiries@mhstar.co.uk

IMPORTER ADDRESS:
MH STAR UK LTD
Unit 27, Perivale Park,
Horsenden lane South
Perivale, UB6 7RH
MADE IN CHINA

Si vous avez la moindre question, veuillez contacter notre centre d'assistance à la clientèle, Nos coordonnées sont les suivantes:

FR

 0033-1-84166106

 aosom@mhfrance.fr

Importé par/Fabricant/REP:
MH FRANCE
2 Rue Maurice Hartmann
92130 Issy Les Moulineaux
France
FABRIQUÉ EN CHINE

Wenn Sie Fragen haben, wenden Sie sich bitte an unser Kundendienstzentrum, Unsere Kontaktdaten stehen unten:

DE

 0049-0(40)-87408465

 service@aosom.de

ADRESSE DES IMPORTEURE/Hersteller/REP:
MH Handel GmbH
Wendenstraße 309
D-20537 Hamburg
Germany
IN CHINA HERGESTELLT

In caso di dubbio, si prega di contattare il nostro centro assistenza clienti, I nostri dettagli di contatto sono di seguito:

IT

 0039-0249471447

 clienti@aosom.it

IMPORTATO DA/Produttore/REP:
AOSOM Italy srl
Centro Direzionale Milanofiori
Strada 1 Palazzo F1
20057 Assago (MI)
P.I.: 08567220960
FATTO IN CINA

Si tiene alguna pregunta, comuníquese con nuestro Centro de Atención al Cliente, Nuestros datos de contacto son los siguientes:

ES

 0034-931294512

 atencioncliente@aosom.es

IMPORTADOR/Fabricante/REP:
SPANISH AOSOM, S.L.
C/ROC GROS, N°15.08550, ELS HOSTALETES DE
BALENYÀ, SPAIN.
B66295775
HECHO EN CHINA

Se tiver alguma dúvida, por favor contacte o nosso Centro de Atendimento ao Cliente, Os nossos dados de contacto são os seguintes:

 0034-931294512

 info@aosom.pt.

IMPORTADOR/Fabricante/REP:
SPANISH AOSOM, S.L.
C.ROC GROS N.15, 08550. ELS HOSTALETES DE
BALENYÀ
FEITO NA CHINA



FR

**DONNEZ
OU
RECYCLEZ**



ASSOCIATION

OU



LIVRAISON

OU



DÉCHÈTERIE

Adresses sur quefairedemesdechets.fr