

FENIX

PANADERO



AFMETINGEN

DIMENSIONS H x L x P	854x796x463 mm
BRUTO/NETTO GEWICHT	180/165 kg
AFMETINGEN DEUR	620x286 mm
ROOKUITGANG	Ø 150-153 mm Verticaal

TECHNISCHE KENMERKEN

GIETIJZEREN ROOSTER	
PANORAMISCH ZICHT	
STALEN PLAAT	5 mm
NOMINAAL VERMOGEN	7 KW
RENDEMENT	80,7%
CO-UITSTOOT	0,12%
HITTEVASTE VERF BESTAND TOT	800°C
KERAMISCH GLAS BESTAND TOT	750°C

EAN 8426964184151
REF. PANADERO 18415

PLUS PRODUCT

ECODESIGN



**EXTERNE
LUCHTTOEVOER**

210
m³

VERWARMINGSVOLUME



BRANDKAMER MET
VERMICULIET



CLSYSTEEMEAN
PLUS



3-VOUDIGE
VERBRANDING



HOUTBLOKKEN
TOT 60 CM



HOUTOPSLAG



DUBBEL SLOT

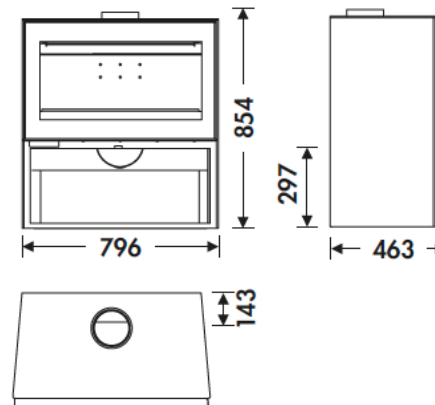

FENIX NL